

**DEVICE
ENGINEERING
INCORPORATED**

385 East Alamo Drive
Chandler, AZ 85225
Phone: (480) 303-0822
Fax: (480) 303-0824
E-mail: admin@deiaz.com

DEI1188

8CH GND/OPEN DISCRETE INTERFACE IC W/ EXT HV PROTECTION

FEATURES

- Eight discrete inputs
 - Senses GND/OPEN discrete signals.
 - Meet input threshold and hysteresis requirements specified per Airbus ABD0100H specification.
 - Thresholds: 4.5V/10.5V, Hysteresis: 3V
 - 1mA input current to prevent dry relay contacts.
 - Internal isolation diode.
 - Uses external series 3Kohm resistors on inputs to implement lightning transient immunity of 1600V and higher. i.e.: DO160E, Section 22, Levels 4 and 5.
 - Inputs protected from Lightning Induced Transients per DO160E, Section 22, Cat A3 and B3 plus waveform 5A to 500V.
- Serial I/O interface to read data register
 - Direct interface to Serial Peripheral Interface (SPI) port.
 - TTL/CMOS compatible inputs and Tristate output
 - 10MHz Max Data Rate
 - Serial input to expand Shift Register
- Pin compatible with DEI1066
- Logic Supply Voltage (VCC): 3.3V +/-5%
- Analog Supply Voltage (VDD): 12.0V to 16.5V
- 16L SOIC EP package

PIN ASSIGNMENTS

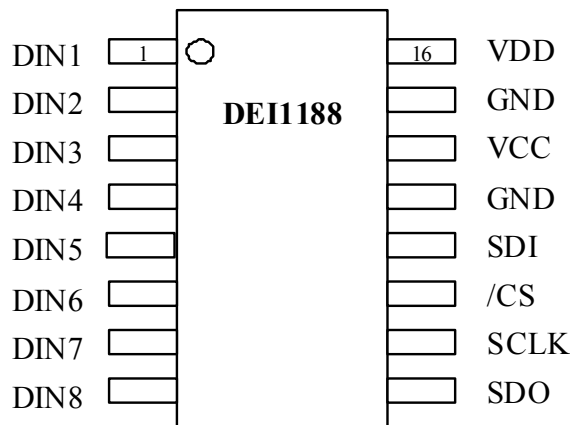

Figure 1 DEI1188 Pin Assignment (16 Lead SOIC)

FUNCTIONAL DESCRIPTION

DEI1188 is an eight-channel discrete-to-digital interface IC implemented in an HV DIMOS technology. It senses eight GND/OPEN discrete signals of the type commonly found in avionic systems and converts them to serial logic data. The discrete data is read from the device via an eight-bit serial shift register with 3-state output. This serial interface is compatible with the industry standard Serial Peripheral Interface (SPI) bus.

The discrete input circuits are designed to achieve a high level of lightning transient immunity. The application design provides a series 3K Ω resistor on each discrete input to achieve DO160E Level 3 and WF5A 500V immunity. Higher immunity levels can be achieved (i.e. Level 5) with the addition of a TVS between the resistor and the input pin.

Table 1 Pin Descriptions

PINS	NAME	DESCRIPTION
1-8	DIN[1:8]	Discrete Inputs. Eight GND/OPEN discrete input signals.
9	SDO	Logic Output. Serial Data Output. This pin is the output from MSB (Bit 8) of the data shift register. It is clocked by the rising edge of SCLK. This is a 3-state output enabled by /CS.
10	SCLK	Logic Input. Serial Shift Clock. A low-to-high transition on this input shifts data on the serial data input into Bit 1 of the selected data register. The data shift register is shifted from Bit 1 to Bit 8. Bit 8 of the data shift register is driven on DOUT.
11	/CS	Logic Input. Chip Select. A low level on this input enables the SDO 3-state output and the data shift register. A high level on this input forces DOUT to the high impedance state and disables the shift registers so SCLK transitions have no effect. A high-to-low transition causes the Discrete Input data to be loaded into the Data Register.
12	SDI	Logic Input. Serial Data Input. Data on this input is shifted into the LSB (Bit 1) of the data shift register on the rising edge of the SCLK when /CS input is low.
13	GND	Logic/Signal Ground
14	VCC	Logic Supply Voltage. 3.3V+/-5%
15	GND	Logic/Signal Ground
16	VDD	Analog Supply Voltage. 12V to 16.5V

ORDERING INFORMATION

Part Number	Marking	Package	Burn In	Temperature
DEI1188-SMS	DEI1188-SMS	16 EP SOIC	No	-55 / +125 °C
DEI1188-SES	DEI1188-SES	16 EP SOIC	No	-55 / +85 °C

DEI reserves the right to make changes to any products or specifications herein. DEI makes no warranty, representation, or guarantee regarding suitability of its products for any particular purpose.

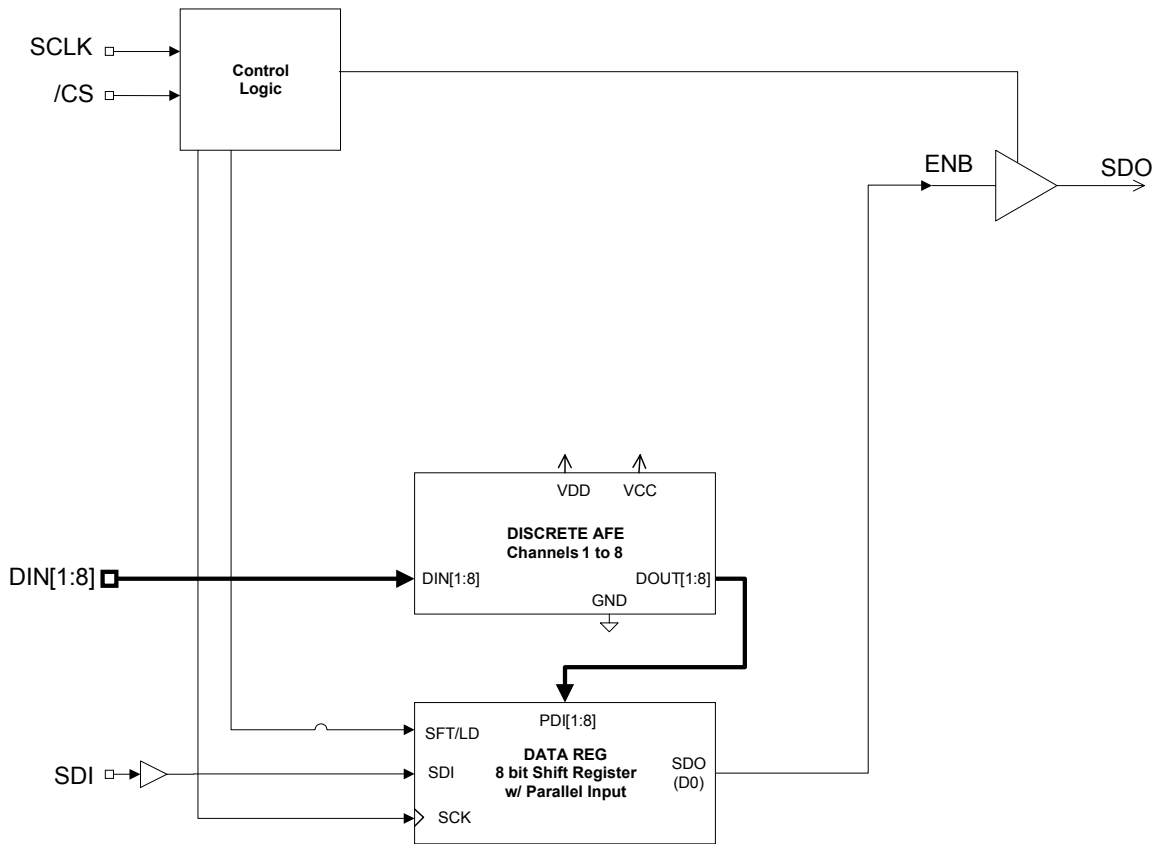

Figure 2 FUNCTION DIAGRAM

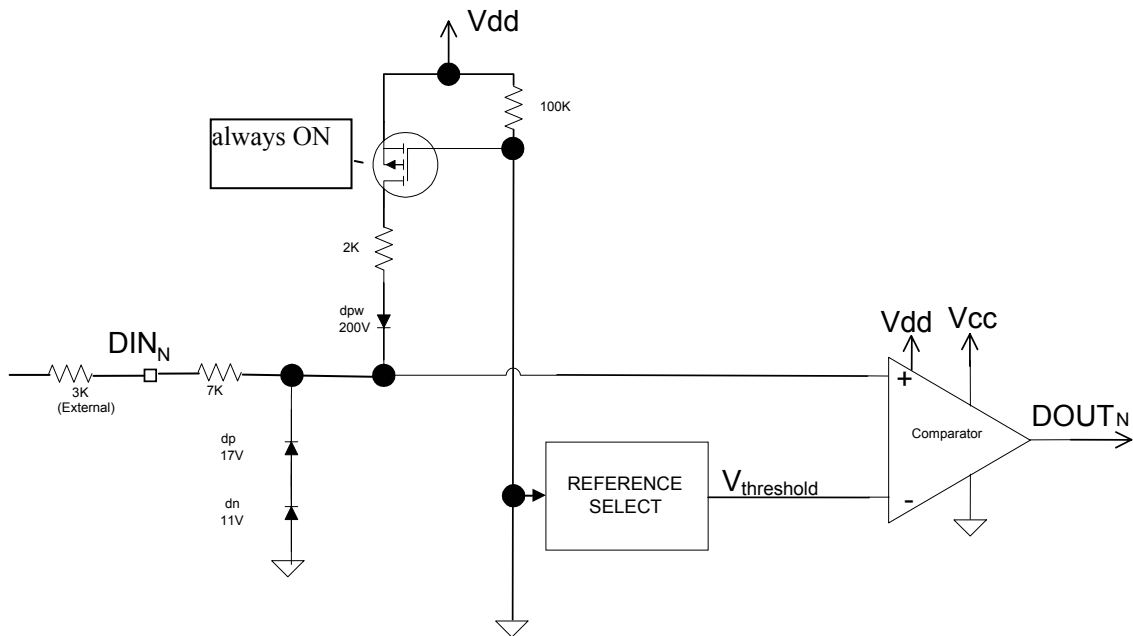

Figure 3 DISCRETE AFE FUNCTION DIAGRAM

Table 2 Truth Table

/CS	SCLK	SDI	DIN[1:8]	SDO	Description
H	X	X	X	HI Z	Not Selected
↓	L	X	Valid	DIN[8]	DR[1:8] ← DIN[1:8]
L	↑	DR[1]	X	DR[8]	DR[n+1] ← DR[n], DR[1] ← SDI
↑	L	X	X	HI Z	Disabled to HI-Z
Legend: DR = Data Register X = Don't Care					

DIN[1:8] Discrete AFE

The Discrete Input Analog Front End circuit function is represented in Figure 3. Each DIN_n signal is conditioned by the resistor / diode network and presented to a comparator with hysteresis. The external 3KΩ resistor is part of the front end circuitry for achieving threshold and hysteresis requirements while protecting the chip from Lightning Induced Transients.

Some notable features are:

- The input current is ~ 1mA. This current will prevent a “dry” relay contact.
- The input threshold voltage and hysteresis:
 - Low-to-high threshold voltage: $10.5V > V_{th} > 9V$.
 - High-to-low threshold voltage: $4.5V < V_{th} < 6V$.
 - Hysteresis: $V_{hys} > 3V$.
- Input noise immunity is maximized with a combination of voltage hysteresis and use of a slow input voltage comparator
- The inputs can withstand continuous input voltages of 49V minimum. The isolation diode breakdown voltage is greater than 42V. The 10K Ohm input resistance (Consists of a 7K Ohm On-Chip resistor and a 3K Ohm Off-Chip resistor) is designed to limit diode breakdown current to safe levels during transient events.

Data Register

The 8-bit Data Register is a “parallel-input, serial-output” register that samples the input channels and reads-out the data to the Serial Data Output. The register is read via the SDO output as described in Figure 4 and Figure 5. A low DIN input level results in a Logic 0, and a high input level results in a Logic 1.

Serial Interface

The DE1188 incorporates a serial IO interface for reading the Discrete Input status. Refer to Figure 2. The interface is SPI compatible and consists of /CS, SCLK, SDO, and SDI signals. Waveform Figures 4 and 5 depict the Data Read sequence and Write sequence for the 8-Bit cycles and also 16 bit “daisy chain” applications.

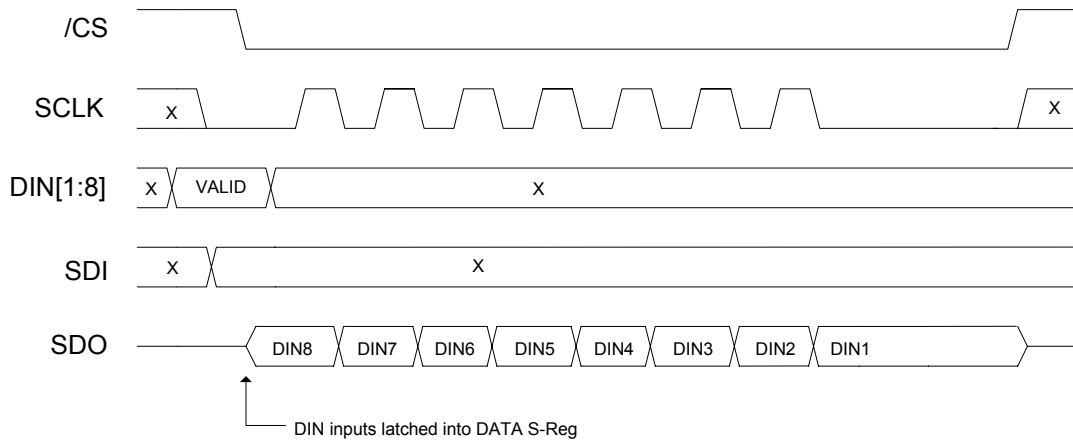

Figure 4 Read Data Register

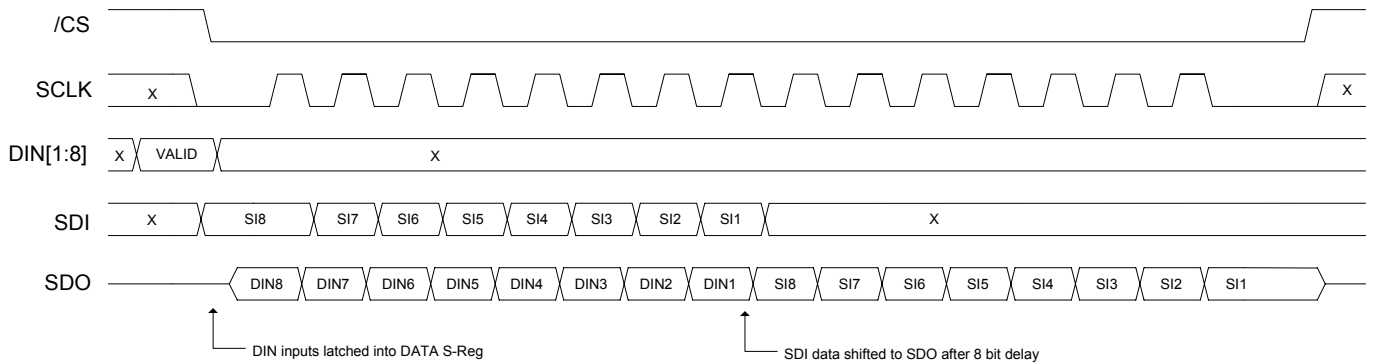

Figure 5 Read Data Register, 16 Bit Daisy Chain

LIGHTNING PROTECTION

DINn inputs are designed to survive lightning induced transients as defined by RTCA DO160E, Section 22, Cat A3 and B3, Waveforms 3, 4, and 5A, Level. They can withstand Level 3 stress and WF5A up to 500V (see figures below) with only the external 3k Ohm series resistor for current limiting. Protection for higher stress levels can be achieved with the addition of transient voltage suppressor (TVS) devices at the DINn pins. Select TVS clamp voltage < 450V. The 3KΩ series resistor limits the TVS surge current.

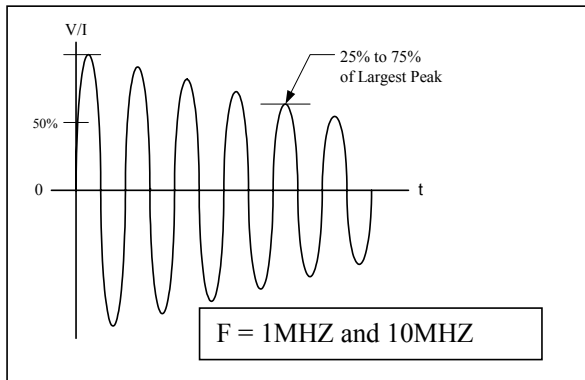

Figure 6 Voltage / Current Waveform 3

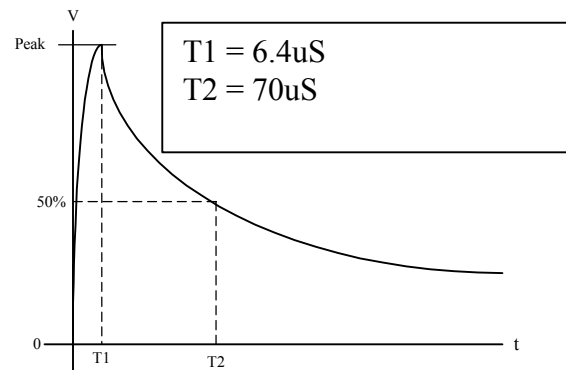

Figure 7 Voltage Waveform 4

Waveform Source Impedance characteristics:

- Waveform 3 $V_{oc}/I_{sc} = 600\text{V} / 24\text{A} \Rightarrow 25\text{ Ohms}$
- Waveform 4 $V_{oc}/I_{sc} = 300\text{V} / 60\text{A} \Rightarrow 5\text{ Ohms}$
- Waveform 5A $V_{oc} / I_{sc} = 300\text{V} / 300\text{A} \Rightarrow 1\text{ Ohm}$
- Waveform 5A $V_{oc} / I_{sc} = 500\text{V} / 500\text{A} \Rightarrow 1\text{ Ohm}$

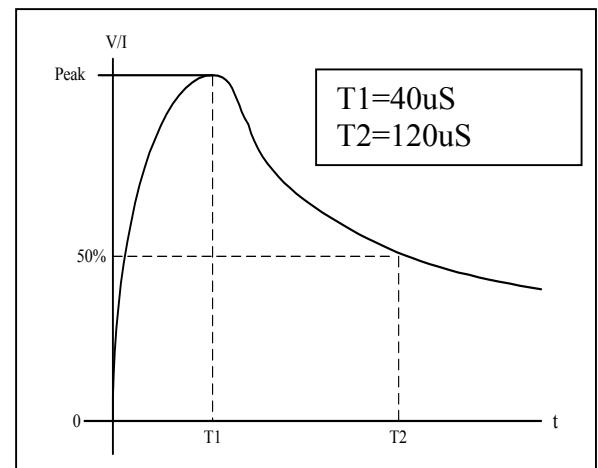

Figure 8 Current/Voltage Waveform 5A

ELECTRICAL DESCRIPTION

Table 3 Absolute Maximum Ratings

PARAMETER	MIN	MAX	UNITS
VCC Supply Voltage	-0.3	+5.0	V
VDD Supply Voltage	-0.3	18	V
Operating Temperature Plastic Package	-55	+125	°C
Storage Temperature Plastic Package	-55	+150	°C
Input Voltage (3) DIN[1:8] Continuous	-10	+49	V
DO160E, Waveform 3, Level 3	-600	+600	V
DO160E, Waveform 4 and 5, Level 3	-300	+300	V
DO160E, Waveform 4 and 5	-500	+500	V
DO160E, Abnormal Surge Voltage, 100ms		80	V
Logic Inputs	-1.5	VCC + 1.5	V
DOUT	-0.5	VCC + 0.5	V
Power Dissipation @ 125 °C, steady state 16L SOIC		0.5	W
Junction Temperature: Tjmax, Plastic Packages		145	°C
ESD per JEDEC A114-A Human Body Model Logic and Supply pins		2000	V
DIN pins		1000	V
Peak Body Temperature (10 sec duration)		235	°C
Notes:			
1. Stresses above absolute maximum ratings may cause permanent damage to the device.			
2. Voltages referenced to Ground			
3. Stress applied to external 3k Ohm series resistor in series with DINn pin.			

Table 4 Recommended Operating Conditions

PARAMETER	SYMBOL	CONDITIONS
Supply Voltage	VCC VDD	3.3V±5% 12.0V to 16.5V
Logic Inputs and Outputs		0 to VCC
Discrete Inputs	DIN[1:8]	0 to 49V
Operating Temperature Plastic	Ta	-55 to +125 °C

Table 5 DC Electrical Characteristics

SYMBOL	PARAMETER	CONDITIONS (1)(2)	LIMITS			UNIT
			MIN	NOM	MAX	
Logic Inputs/Outputs						
V _{IH}	HI level input voltage	VCC = 3.3V	2.0			V
V _{IL}	LO level input voltage				0.8	V
V _{Ihst}	Input hysteresis voltage, SCLK input	(3)	50			mV
V _{OH}	HI level output voltage	IOUT = -20uA	VCC - 0.1			V
		IOUT = -4mA, VCC = 3V	2.4			V
V _{OL}	LO level output voltage	IOUT = 20uA			0.1	V
		IOUT = 4mA, VCC = 3V			0.4	V
I _{IN}	Input leakage	VIN = VCC or GND	-10		10	uA
I _{OZ}	3-state leakage current	Output in Hi Impedance state. VOUT = VIHmin, VILmax	-10		10	uA
Discrete Inputs (4)						
V _{IH}	HI level input voltage		10.5		49	V
VT _{LH}	Input Threshold Voltage, Low to High		9.0		10.5	V
R _{IH}	HI level Din-to-GND resistance	Resistor from Din to GND to guarantee HI input condition.	50K			Ohms
I _{IH}	HI level input current	VIN = 28V, VDD = 15V	330	660	990	nA
		VIN = 49V, VDD = 15V		0.8		mA
V _{IL}	LO level input voltage		-3.0		4.5	V
VT _{HL}	Input Threshold Voltage, High to Low		4.5		6.0	V
R _{IL}	LO level Din-to-GND resistance	Resistor from Din to GND to guarantee LO input condition.			500	Ohms
I _{IL}	LO level input current	VIN = 0V, VDD = 15V	-0.8	-1.3	-1.8	mA
V _{Ihst}	Input hysteresis voltage		3			V
Power Supply						
ICC	Max quiescent logic supply current	VIN(logic) = VCC or GND VIN[1:8]= open		1.8	3	mA
IDD	Max quiescent analog supply current	VIN(logic) = VCC or GND VIN[1:8]= Open		15	24	mA
		VIN[1:8]= GND, All configured as Ground/Open		22	33	
Notes: <ol style="list-style-type: none"> Ta = -55 to +125 °C. VDD = 12.0 to 16.5V, VCC = 3.3+/-5% unless otherwise noted. Current flowing into device is '+'. Current flowing out of device is '-'. Voltages are referenced to Ground. Guaranteed by design. Not production tested. With 3k Ohm, 2% resistor in series with DIN input pin. 						

Table 6 AC Electrical Characteristics (4)

SYMBOL	PARAMETER	CONDITIONS (6, 7)	LIMITS		UNIT
			Min	Max	
f_{MAX}	SCLK frequency. (50% duty cycle) (5)		0.1	10	MHz
t_w	SCLK pulse width. (5)		50		ns
t_{su1}	Setup time, SCLK low to /CS↓.		30		ns
t_{h1}	Hold time, /CS↓ to SCLK↑.		25		ns
t_{su2}	Setup time, DIN valid to /CS↓.		500		ns
t_{h2}	Hold time, /CS↓ to DIN not valid.		15		ns
t_{su3}	Setup time, SDIN valid to SCLK↑.		25		ns
t_{h3}	Hold time, SCLK↑ to SDIN not valid.		25		ns
t_{p1}	Propagation delay, /CS↓ to DOUT valid.(1)			105	ns
t_{p2}	Propagation delay, SCLK↑ to DOUT valid.(1)			90	ns
t_{p3}	Propagation delay, /CS↑ to DOUT HI-Z. (1) (2) (3)			80	ns
t_{p4}	Delay time between /CS active. (5)		20		ns
C_{in}	Maximum logic input pin Capacitance. (5)			10	pf
C_{out}	Maximum DOUT pin capacitance, output in HI-Z state. (5)			15	pf

Notes:

1. DOUT loaded with 50pF to GND.
2. DOUT loaded with 1K Ohms to GND for Hi output, 1K Ohms to VCC for Low output.
3. Timing measured at 25%VCC for “0” to Hi-Z, 75%VCC for “1” to Hi-Z.
4. Sample tested on lot basis.
5. Not tested
6. $T_a = -55$ to $+125^\circ\text{C}$. $V_{DD} = 12\text{V}$, $V_{CC} = 3\text{V}$. $V_{IL} = 0\text{V}$, $V_{IH} = V_{CC}$ unless otherwise noted.
7. Measurements made at 50%VCC.

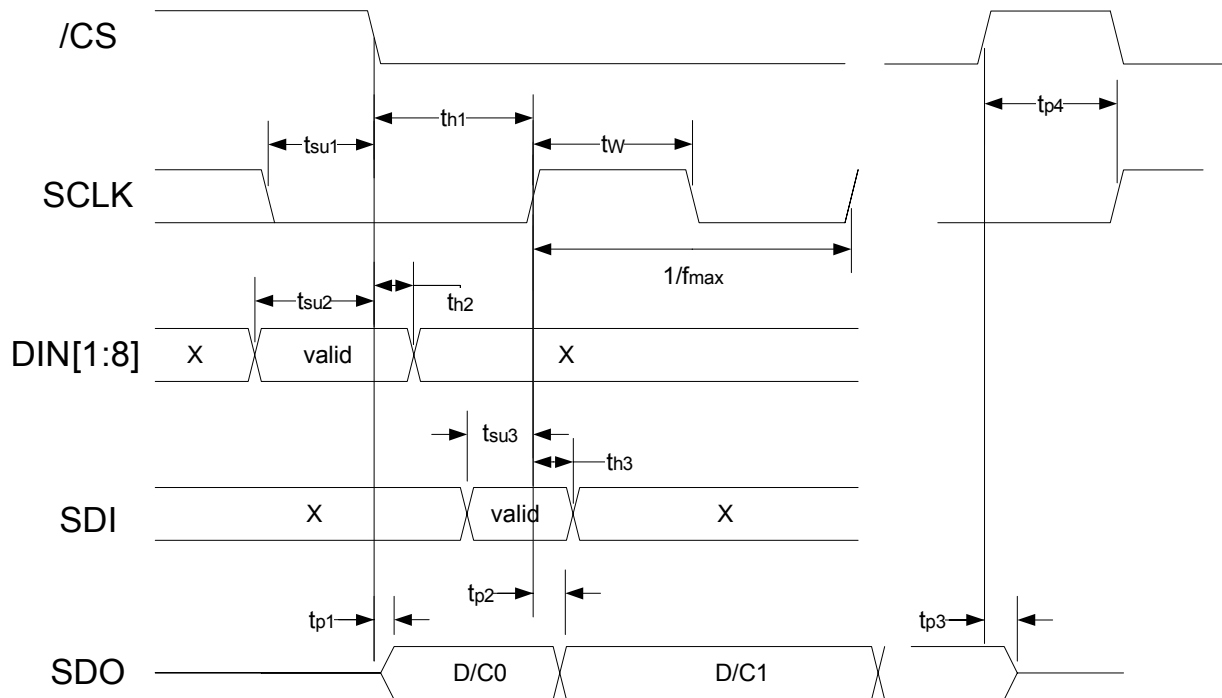

Figure 9 Switching Waveforms

APPLICATION INFORMATION

Discrete Input Filtering

The DEI1188 Analog Front End provides a moderate level of noise immunity via a combination hysteresis and limited bandwidth. The Hysteresis is 3V minimum and the comparator bandwidth is approximately 10Mhz.

Many applications provide additional noise immunity by means of debounce/filtering in software or in digital circuitry (i.e.: FPGA). Common input debounce techniques are readily found with a web search of the term “software debounce” and range from simple detectors of two or more sequential stable readings to FIR filters emulating RC time constants.

Input Current Characteristics

The DIN Input Current vs. Voltage characteristics are shown in Figure 10.

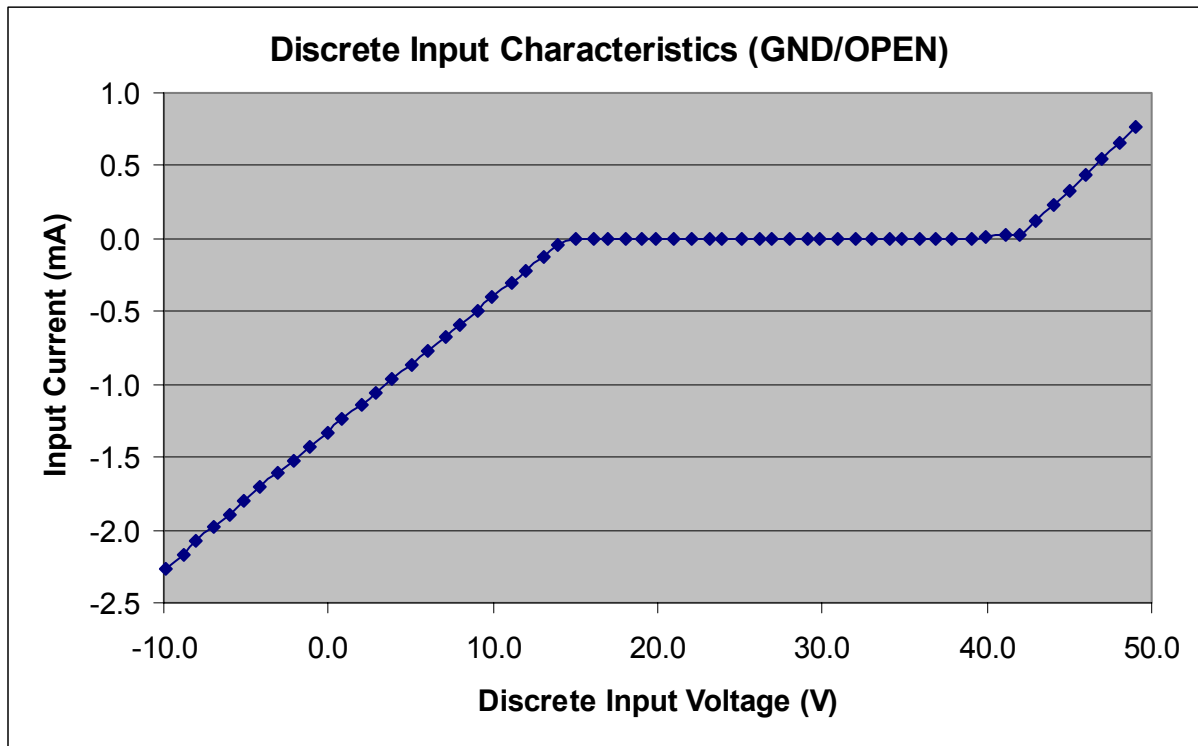

Figure 10 Input IV Characteristics (VDD=15V)

Package Power Dissipation

The DE1188 power dissipation varies with operating conditions. Figure 11 shows the device package power dissipation for various operating conditions. This includes the contributions from Supply currents and DIN Input currents. The curves are as follows:

Table 7 Legend for Power Dissipation Curves

CURVE ID	SUPPLY VOLTAGE, TEMPERATURE, IC VARIATION
GND/OPEN-Nom	3.3V, 12V / 27°C / typical IC parameters
GND/OPEN-Wst	3.3V, 16.5V / 125°C / Worst case IC parameters

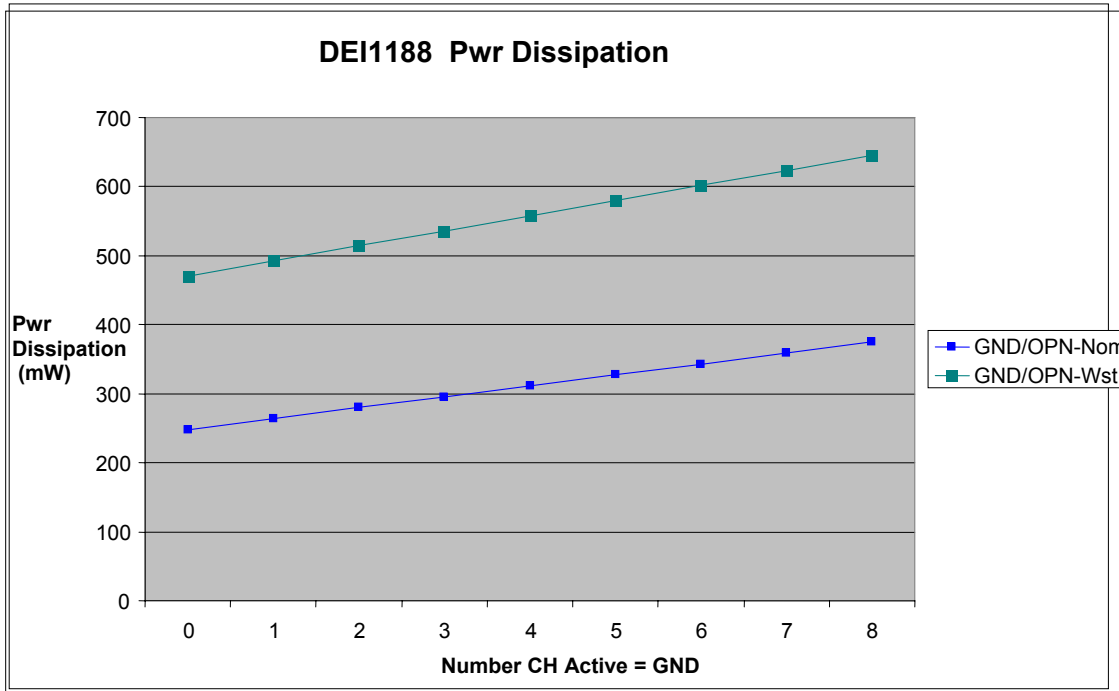

Figure 11 Power Dissipation for Various Conditions

PACKAGE DESCRIPTION - 16L Narrow Body EP SOIC

Moisture Sensitivity:	Level 2 / 235°C per JEDEC J-STD-020A (1yr floor life)
Θ_{ja} :	~40°C/W (Mounted on 4 layer PCB with exposed pad soldered to PCB land with thermal vias to internal GND plane)
Θ_{jc} :	~10°C/W
Lead Finish:	SnPb plated
Exposed Pad:	Electrically Isolated from IC terminals.

The PCB design and layout is a significant factor in determining thermal resistance (Θ_{ja}) of the IC package. Use maximum trace width on all power and signal connections at the IC. These traces serve as heat spreaders which improve heat flow from the IC leads. The exposed heat sink pad of the SOIC package should be soldered to a heat-spreader land pattern on the PCB. The IC exposed pad is electrically isolated, so the PCB land may be at any potential, typically GND, for the best heat sink. Maximize the PCB land size by extending it beyond the IC outline if possible. A grid of thermal VIAs, which drop down and connect to the buried copper plane(s), should be placed under the heat-spreader land. A typical VIA grid is 12mil holes on a 50mil pitch. The barrel is plated to about 1.0 ounce copper. Use as many VIAs as space allows. VIAs should be plugged to prevent voids being formed between the exposed pad and PCB heat-spreader land due to solder escaping by the capillary effect. This can be avoided by tenting the VIAs with solder mask.

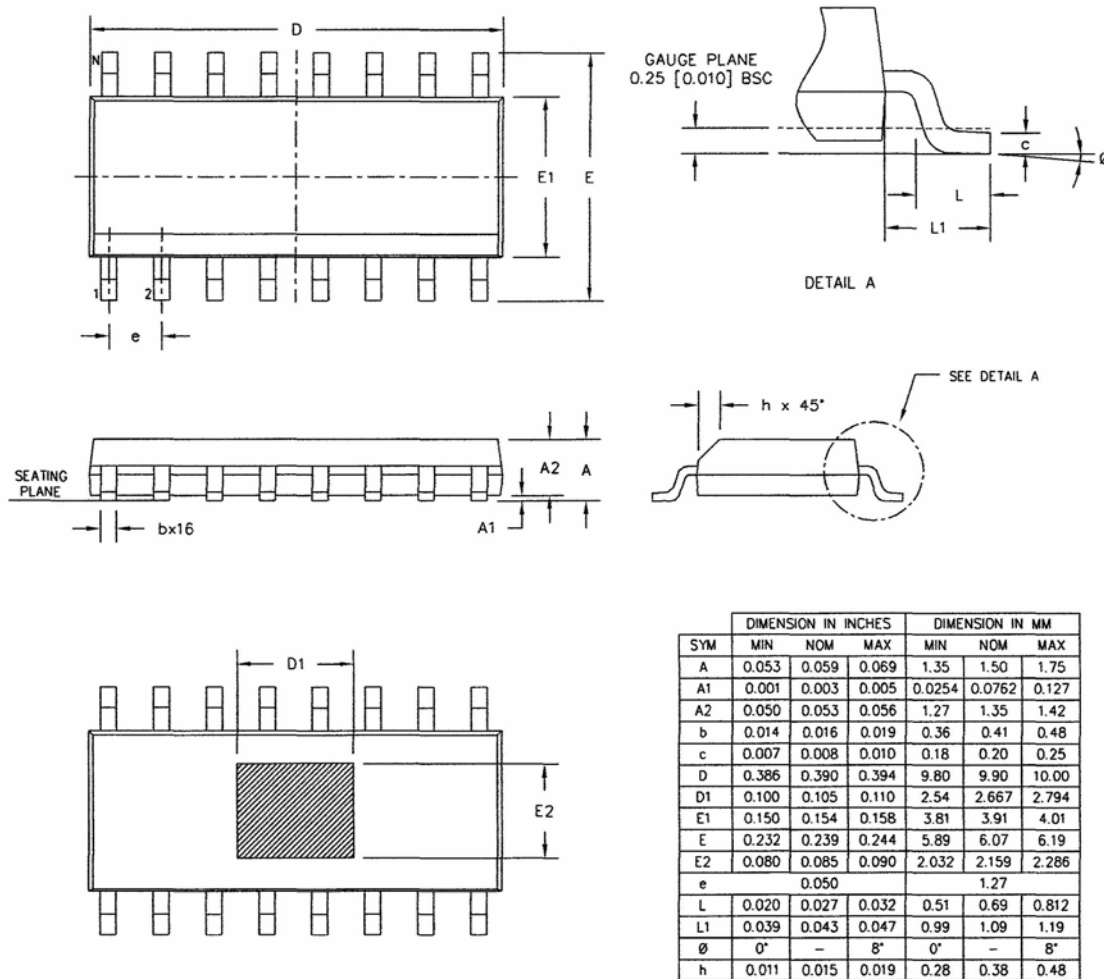

Figure 12 16 Lead Narrow Body EP SOIC Outline