

**DEVICE
ENGINEERING
INCORPORATED**

385 East Alamo Drive
Chandler, AZ 85225
Phone: (480) 303-0822
Fax: (480) 303-0824
E-mail: admin@deiaz.com

**DEI1170A, DEI1171A
ARINC 429 LINE DRIVER WITH
RATE SELECT and TRI-STATE**

FEATURES

- TTL/CMOS to ARINC 429 Line Driver
- HI/LO Speed Control Pin for Hi (100KBS) or Lo (12.5KBS) speed slew rates
- $\pm 9.5V$ to $\pm 16.5V$ supplies
- Drives full ARINC load
- Output resistor options: 0, 10 or 37.5 Ohms
- Tristate Output feature
- Thermally enhanced 5 x 5 mm MLP package
- The DEI1170A family is an improved version of the popular DEI1170 family

GENERAL DESCRIPTION

The DEI1170A/DEI1171A bipolar integrated circuits are line drivers designed to directly drive the ARINC 429 avionics serial digital data bus. The device converts TTL/CMOS serial input data to the tri-level RZ bipolar differential modulation format of the ARINC bus. A TTL/CMOS control input selects the output slew rate for HI (100KBS) and LOW (12.5KBS) speed operation. No external timing capacitors are required. A429 output tri-state capability is enabled by the TS_CTL input.

The DEI1170A/1A Line Drivers are an improved version of the popular DEI1170/1 family. They provide:

- Lower power consumption
- Excellent waveform fidelity
- Improved transient immunity. This improvement simplifies the equipment design for lightning and RF immunity requirements.

The Line Driver provides output resistor values and output tri-state capability (see table 1). There are three output resistor options: 0 Ω , 10 Ω and 37 Ω . The 0 Ω and 10 Ω versions require external resistors to achieve the 37 Ω output resistance of the ARINC 429 standard. The external resistors are normally used to simplify the external transient voltage protection network. The outputs are tri-state capable. This feature is useful in non-standard applications where there are multiple drivers on a wire pair.

TERMINAL DESCRIPTION

Notes:

1. Package: 20 Lead 5.0 x 5.0mm MLP
2. Exposed Pad is connected V- Supply on DEI1170A.
Exposed Pad is electrically isolated on DEI1171A.

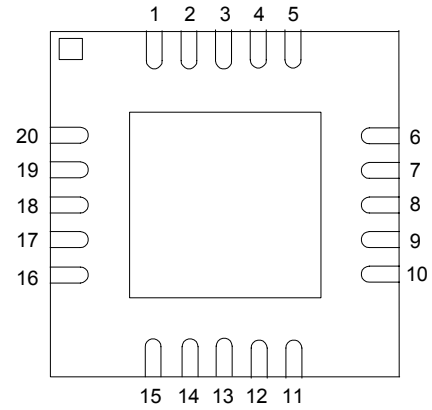

BOTTOM VIEW

Table 1 Pin Description

SIGNAL NAME	PIN	DESCRIPTION
HI/LO	15	LOGIC INPUT. Slew rate control. 1 = Hi speed. 0 = Low speed.
TTLIN0	17	LOGIC INPUT. Serial digital data input 0.
TTLIN1	18	LOGIC INPUT. Serial digital data input 1.
TS_CTL	1	LOGIC INPUT. Open or '1' disables output Tristate function. '0' Enables output Tristate function.
429OUTA_0	7	429 OUTPUT. ARINC 429 format serial digital data output A, 0 Ohm
429OUTA_10	6	429 OUTPUT. ARINC 429 format serial digital data output A, 10 Ohm
429OUTA_37	5	429 OUTPUT. ARINC 429 format serial digital data output A, 37 Ohm
429OUTB_0	9	429 OUTPUT. ARINC 429 format serial digital data output B, 0 Ohm
429OUTB_10	10	429 OUTPUT. ARINC 429 format serial digital data output B, 10 Ohm
429OUTB_37	11	429 OUTPUT. ARINC 429 format serial digital data output B, 37 Ohm
V+	12	POWER INPUT. +9.5 to +16.5 VDC.
GND	19	POWER INPUT. Ground.
V-	4	POWER INPUT. -9.5 to -16.5 VDC
NC	2, 3, 8, 13, 14, 16, 20	No Internal Connect

FUNCTIONAL DESCRIPTION

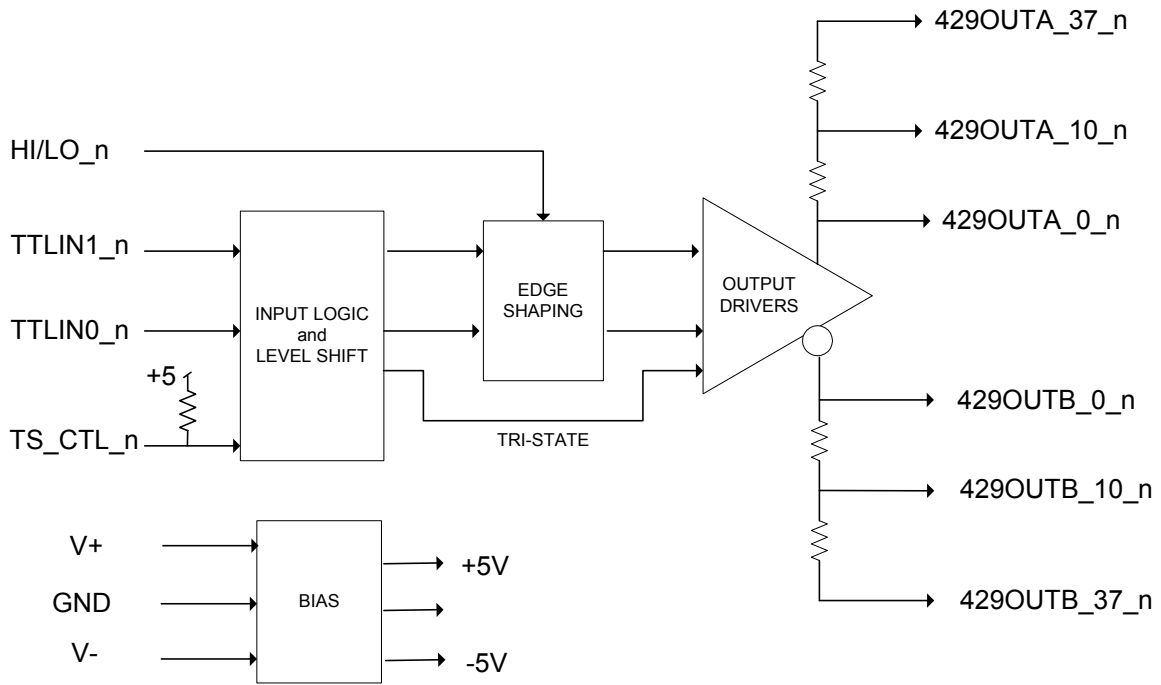

Figure 1 Block Diagram

Table 2 Speed Control Function Table

HI/LO	OUTPUT TRANSITION TIME
L	10uS (12.5KBS data)
H	1.5uS (100KBS data)

Table 3 Transmit Data Function Table

TS_CTL_n	TTLIN1_n	TTLIN0_n	429OUTA	429OUTB	NOTES
X	0	0	0V	0V	Null output
X	0	1	-5V	5V	Zero output
X	1	0	5V	-5V	One output
1	1	1	0V	0V	Null output
0	1	1	Hi-Z	Hi-Z	Tri-state Output

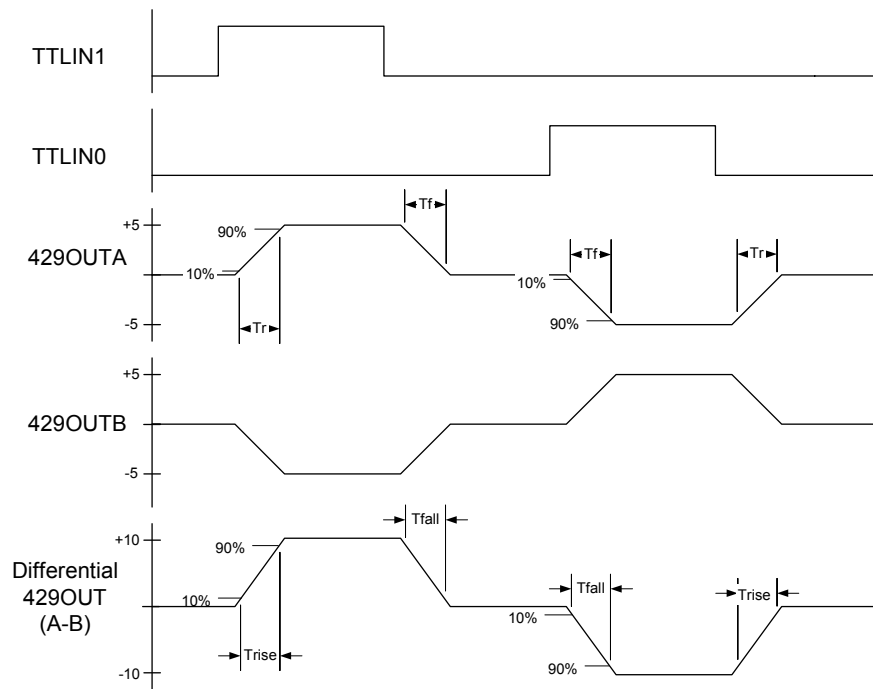

Figure 2 Line Driver Waveforms

ELECTRICAL DESCRIPTION

Table 4 Absolute Maximum Ratings

PARAMETER	MIN	MAX	UNITS
V+ Supply Voltage	-0.3	+20	V
V- Supply Voltage	0.3	-20	V
Storage Temperature	-65	+150	°C
Input Voltage TTLIN, HI/LO, AND TS_CTL Inputs 429OUT Outputs (175uS surge)	Gnd - 0.5	'V+' + 0.5	V
0 Ohm Output	'V-' - 1.0	'V+' + 1.0	V
10 Ohm Output	'V-' - 5.0	'V+' + 5.0	V
37 Ohm Output	'V-' - 20	'V-' - 20	V
Input Current 429OUT Outputs (175uS surge)	-0.5	0.5	A
Power Dissipation @ 85°C 20L MLPQ, thermal pad soldered to heat spreader land		TBD	W
Junction Temperature: Tjmax		150	°C
ESD per JEDEC A114-A Human Body Model		2000	V
Peak body Temperature: 20L MLPQ		260	°C
Notes:			
1. Stresses above absolute maximum ratings may cause permanent damage to the device.			
2. The device is tolerant of one or both outputs shorted to Ground and of both outputs shorted together.			
3. Voltages referenced to Ground			

Table 5 Recommended Operating Conditions

PARAMETER	SYMBOL	CONDITIONS
Supply Voltage	V+ V-	9.5 to 16.5V -9.5 to -16.5V
Operating Temperature -xEx parts -xMx parts	T _{op}	-55 to +85 °C -55 to +125 °C

Table 6 Electrical Characteristics

PARAMETER	TEST CONDITIONS (1)	SYMBOL	MIN	NOM	MAX	UNITS
LOGIC INPUTS						
Input Voltage, Logic 1		V _{IH}	2.0		V+	V
Input Voltage, Logic 0		V _{IL}	-0.3		0.8	V
Input Current, Logic 1	V _{IN} = 5.0V	I _{IH}	0	25	100	uA
Input Current, Logic 0	V _{IN} = 0.0V	I _{IL}	0	-20	-100	uA
ARINC OUTPUTS						
ARINC Output Voltage HI NULL LO	Single Ended Referenced to Ground No Load.	V _{oHI} V _{oNULL} V _{oLO}	4.5 -0.25 -5.5	5.0 0 -5.0	5.5 +0.25 -4.5	V V V
Output Tristate Leakage Current	Force output to -5V and +5V	I _z	-200		+200	uA
ARINC Output Short Circuit Current 0 Ohm output	External 37.5Ω resistor to GND	I _{scLO} I _{scHI}	100 -146	133 -133	146 -100	mA mA
Output Resistance: 37 Ohm Output 10 Ohm Output 0 Ohm Output	Room Temperature Calculated from delta-V _{out} / delta-I _{load} Where I _{load} = 0 and 20mA See Figure 3	R _{out37} R _{out10} R _{out0}	24.3 6.5 0	37.5 10 0.2	50 13.5 2.0	Ohms Ohms Ohms
Output Slew Rate, Hi Speed Lo to Hi and Hi to Lo transitions	HI/LO = 1 No Load, 10% to 90% single ended output	T _r /T _f	1		2	uS
Output Slew Rate, Lo Speed Lo to Hi and Hi to Lo transitions	HI/LO = 0 No Load, 10% to 90% single ended output 0°C to +125°C -55°C to +125°C	T _r /T _f	5 5		15 17	uS uS
SUPPLY CURRENT						
Quiescent Operating Supply Current: IV+ IV-	V+ = 15V, V- = -15V HI/LO = 0 or 1 TTLIN0=TTLIN1= 0V No Load	IV+ IV-	- -6.0	3.0 -2.5	6.0 -	mA mA
Notes:						
<ol style="list-style-type: none"> General Conditions: T_{case} = rated operating temperature, -55/+85°C or -55/+125°C. V_{+/-} = +/-9.5 to +/-16.5V Unless otherwise noted, currents flowing in to DUT are positive, currents flowing out of DUT are negative, voltages are referenced to Ground. Not production tested. 						

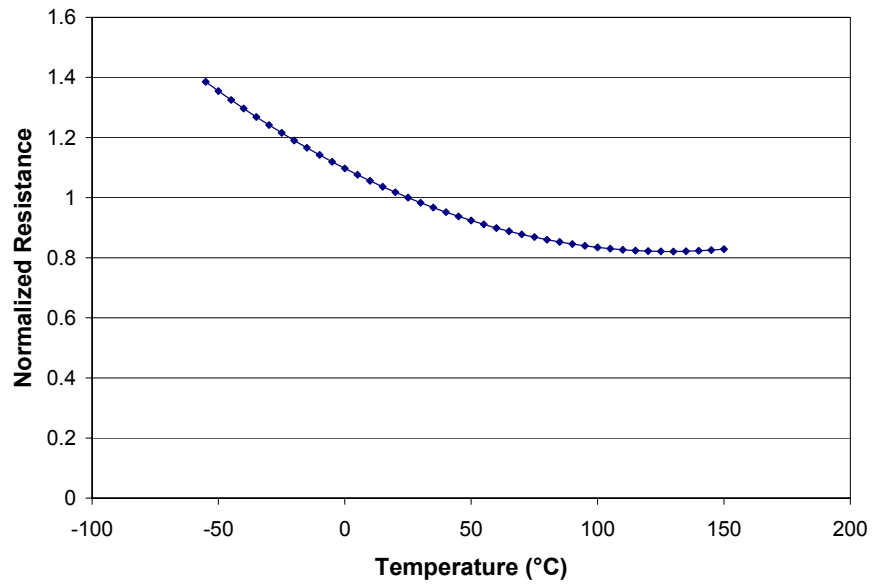

Figure 3 Normalized Output Resistance vs. Temperature

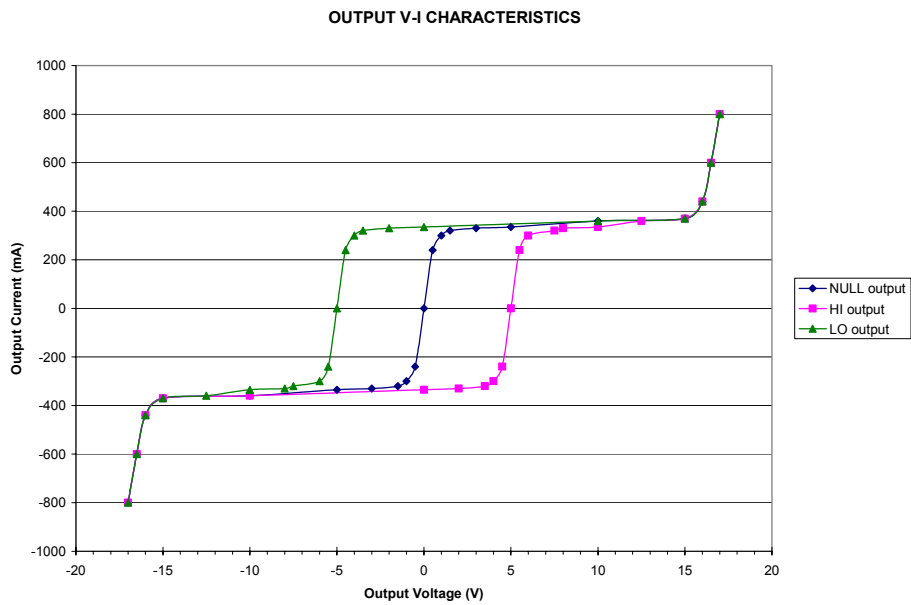

Figure 4 429OUT V-I Characteristics, ±15V supplies

DESIGN CONSIDERATIONS

Power Supplies and Bypass Capacitors

The DEI117XA Line Driver operates from $\pm 9.5V$ to $\pm 16.5V$ dual supplies. Proper bypassing ensures stability while driving large capacitive loads. The Line Driver requires a minimum of a 0.1 μF bypass capacitor placed as close as possible to the V+ and V- pins.

Transient Voltage Protection

The DEI117XA Line Driver requires external components to achieve immunity from surges such as those defined by DO160D Section 22, "Lightning Induced Transient Susceptibility". Typical surge protection includes silicon Transient Voltage Suppressor (TVS) devices and may include all or part of the 37.5 Ohm output resistance as external resistors to limit the surge current.

The 117xA has a robust output stage which includes large driver devices and clamp diodes to the V+ and V- power rails as shown in Figure 5. It withstands surge currents of $\pm 0.5A$ for 175 μs without damage when powered with $\pm 15V$ supplies. At that surge current, the diodes clamp at $\sim 1V$ above (below) the V+ (V-) supply rail. $\sim 350mA$ flows to the V- (V+) supply through the output amplifier, and $\sim 150mA$ flows to the V+ (V-) supply through the clamp diode. The outputs may be damaged by surges greater than 1A / 175 μs . At that current, the diodes clamp at $\sim 1.8V$ above (below) the supply.

Figure 5 Surge Protection Network

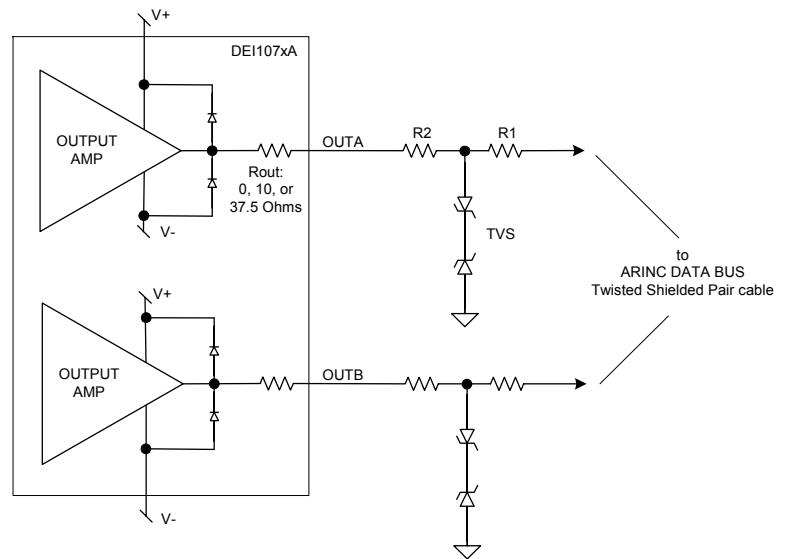

The external lightning protection network should be designed to meet the specific requirements and constraints of the application equipment. The protection network should limit the OUTA/B pin surge current to the 0.5A / 175 μs maximum. The generalized circuit of Figure 5 represents several TVS protection network options:

- The on-chip R_{out} value is 0, 10, or 37 Ohms depending on the output pin used
- Select the total output resistance, $R_{out} + R1 + R2 = 37$ Ohms to meet ARINC bus requirements
 - Select $R1 = 37\Omega$, $R2 = 0\Omega$, $R_{out} = 0\Omega$ for lowest TVS surge current rating (smallest TVS devices)
 - Select $R1 = 0\Omega$, $R_{out} + R2 = 37\Omega$ for highest TVS clamp voltage ($20V + V_{+/-}$)
 - If the V+/V- supplies are un-powered or below operating voltage during the surge event, large currents may flow through the internal clamp diodes and damage the driver. If the application requires lightning immunity while un-powered, Select $R1 = 0\Omega$, $R_{out} + R2 = 37\Omega$, and select the TVS clamp voltage for $<20V$.
- Select TVS devices for the following
 - TVS Surge power/current rating must withstand the application requirements for Lightning Induced Transient Levels and Waveforms. Microsemi Corporation publishes an application note specific to the DO160 lightning requirements, available at: <http://www.microsemi.com/micnotes/126.pdf>
 - Select low capacitance TVS devices to minimize the load on the line driver. (Examples: Microsemi LC and HSMBJSA series TVS) This is a priority for Hi Speed ARINC applications where the low capacitance is important for optimum signal integrity and power consumption. Note that the maximum total capacitance on the ARINC bus is 30nF line to line.
 - Select the TVS clamp voltage at the lightning surge conditions such that the voltage/current into the 117XA OUT pin is within the safe region.
- If R1 is used to limit the TVS surge current, the resistor must withstand the surge current and voltage.

Alternate protection methods may be appropriate in some applications.

- External clamp diodes to the supply rails may be used to shunt surge current to the supply rails rather than to Ground.
- PTC "resettable fuses" may be used for R1 to protect the driver and TVS from shorts to 28V aircraft power.

Some general considerations related to Lightning Immunity:

- Analyze the TVS high current signal and ground return path to insure adequate surge current capability. The IR voltage and $L \cdot di/dt$ voltage in the ground return will add additional stress beyond the TVS clamp voltage.
- Observe suitable PCB design rules for traces subject to high voltage and high current surges.
- When possible, locate TVS devices close to the equipment connector to minimize the length of the surge voltage/current traces within the equipment.
- The shields of ARINC 429 data bus cables should be terminated to aircraft ground at all ends and at all bulkhead disconnects.

Thermal Management

Good thermal management is fundamental to Line Driver device reliability. It is particularly important in designs operating at the HI speed data rate (100KBS) with high capacitive loads as this produces maximum power dissipation. While the 117xA device will function at a junction temperature (T_j) above 190°C, it is inappropriate to continuously operate the plastic package above 150°C. Like all microcircuits, long term reliability is improved with lower operating temperatures.

The Line Driver's operating T_j is determined by internal power dissipation, package thermal resistance, and ambient temperature. The internal power dissipation (P_d) varies greatly with several variables:

- Data Rate – The Hi Speed (100kbs) rate produces maximum power dissipation
- Load – The maximum ARINC 429 load is 30nF||400 Ω line-to-line. Many applications only drive a fraction of the full load.
- Data Duty Cycle - ARINC bus activity, averaged over 10 seconds = Bits transmitted / total possible bits. Many applications are active <70%.
- Supply Voltage – $V+/V-$ supply range is from $\pm 9.5V$ to $\pm 16.5V$. Higher voltage => higher power
- Rout configuration - The power dissipated in the two 37 Ω output resistors is internal to the IC for the 37 Ohm output configuration, and external for the 0 Ohm output configuration.

The internal power dissipation for 100kbs applications can be estimated from Figure 6. P_d for low speed operation (12.5kbs) is normally not an issue, so is not considered here. The curves in Figure 6 indicate P_d for various loads, supply voltage, and Rout configuration. It represents P_d for 100% Data Duty Cycle at 100KBS with no word gap null times. Thus the indicated P_d values are considered maximum values and should be reduced to account for the Data Duty Cycle as follows:

- Estimate DDC = total bits transmitted in 10 sec period / 1,000,000
= 32 x total ARINC words transmitted in 10 sec period / 1,000,000
- Use Figure 6 to select an indicated P_d for the application supply voltage and load. This may involve estimating the Line Driver's load and interpolating between the curves.
- Calculate adjusted P_d = DDC * (P_d - 0.1) + 0.1 (W)

The operating junction temperature is calculated as follows:

$$T_j = T_a + P_d \cdot \Theta_{ja}$$

where

T_j = junction temperature (°C)

T_a = Ambient temperature (°C)

P_d = Internal power dissipation (W)

Θ_{ja} = IC package thermal resistance from junction to ambient (°C/W). Refer to package details.

The ARINC 429 Line Driver outputs may be subject to short circuit conditions due to cable wiring errors or faults which typically occur during equipment test and aircraft installation environments. The common cases are one or both outputs shorted to Ground, or both outputs shorted together. These conditions may cause considerable internal power dissipation depending on the following:

- Data Duty Cycle – The line-to-line and line-to-Ground shorts cause little or no power dissipation when the outputs are in the Null state. However when the output is driving a HI/LO state, the short circuit current is limited by the 37.5 Ω Rout at about ~133mA. This is modulated by the ARINC waveform, producing an effective current of ~88mA* DDC. This current causes heating in the output amplifier and Rout resistor.
- Supply Voltage – A lower supply voltage results in lower P_d during short circuit conditions. The internal P_d for both outputs shorted while operating at 100% DDC is ~2W with $\pm 15V$ supplies, but is reduced to ~1.5W with $\pm 12V$ supplies. This is for 0 Ω Rout configurations.

- Rout configuration – Each of the two 37.5Ω Rout resistors dissipates ~0.29W when shorted at 100% DDC. This power is dissipated in the external resistors for the 0 Ohm output configuration, and internal to the IC for the 37 Ohm output configuration. Thus the 0 Ohm and 10 Ohm configurations have a lower Tj and are more tolerant to short circuit conditions.

The PCB design and layout is a significant factor in determining thermal resistance (θ_{ja}) of the Line Driver IC package. Use maximum trace width on all power and signal connections at the IC. These traces serve as heat spreaders which improve heat flow from the IC terminals. The exposed heat sink pad of the MLP package should be soldered to a heat-spreader land pattern on the PCB designed to maximize heat flow to the inner layer Ground/Power planes. The land should include a grid of thermal VIAs, which drop down and connect to the buried copper plane(s). A typical VIA grid is 12mil holes on a 50mil pitch. The barrel is plated to about 1.0 ounce copper. Use as many VIAs as space allows. VIAs should be plugged to prevent voids being formed between the exposed pad and PCB heat-spreader land due to solder escaping by the capillary effect. This can be avoided by tenting the VIAs with solder mask. The 1171A exposed pad is electrically isolated, so the PCB land may be at any potential; typically Ground for the best heat sink. The 1170A exposed pad is electrically connected to the V- supply, so the PCB land must either be connected to that supply voltage or be electrically isolated. The thermal resistance of the 1170A package is lower than the 1171A because the electrically conductive die attach has superior thermal properties.

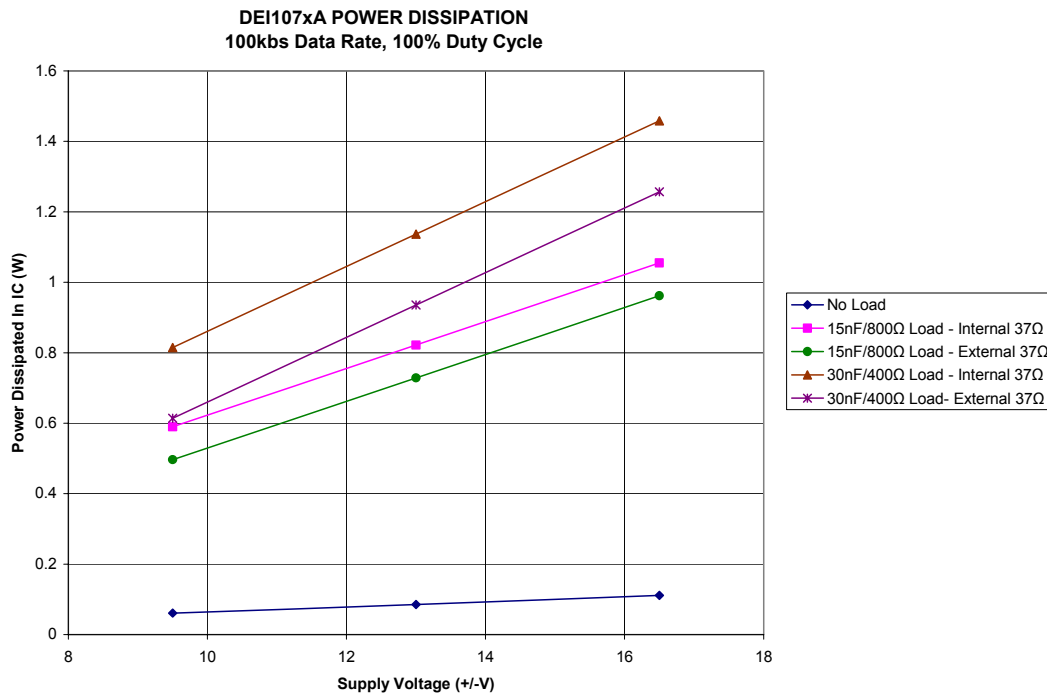

Figure 6 Internal Power Dissipation

ORDERING INFORMATION

Part Number	Marking	Package	Temperature
DEI1170A-MES-G	DE1170AMES	20L MLP - conductive	-55 / +85 °C
DEI1171A-MES-G	DE1171AMES	20L MLP- isolated	-55 / +85 °C
DEI1170A-MMS-G	DE1170AMMS	20L MLP - conductive	-55 / +125 °C
DEI1171A-MMS-G	DE1171AMMS	20L MLP- isolated	-55 / +125 °C

DEI reserves the right to make changes to any products or specifications herein. DEI makes no warranty, representation, or guarantee regarding suitability of its products for any particular purpose.

PACKAGE DESCRIPTION

20 Lead 5.0 x 5.0 MLP

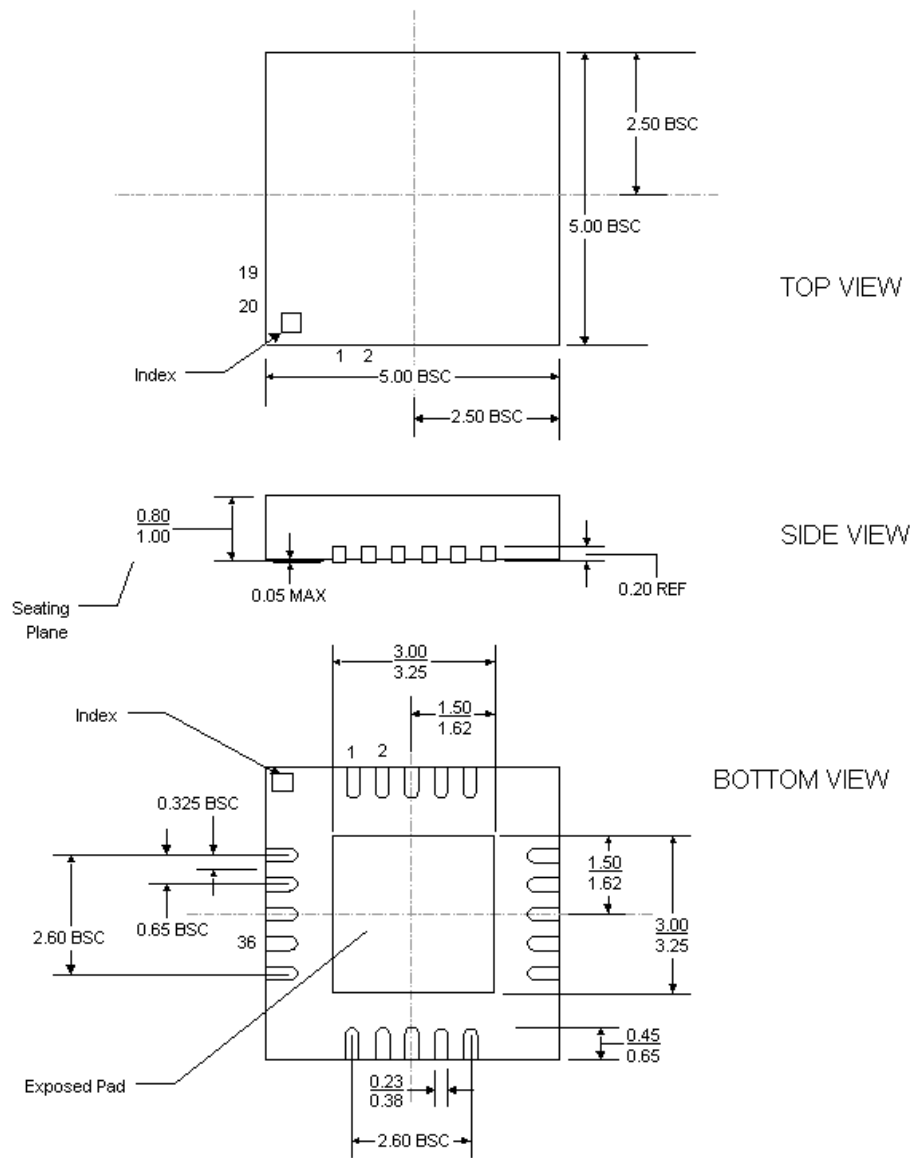

Dimensions in mm

Table 7 20L MLP Characteristics

SYMBOL	DESCRIPTION	VALUE	UNITS
Theta _{ja}	Junction to Ambient. DEI1170A - Conductive pad DEI1171A - Isolated Pad	~37 ~41	°C/W
MSL	JEDEC Moisture Sensitivity Level Peak Body Temperature	3 260	- °C
This package is RoHS compliant. Lead finish is NiPdAu			