

# DEI1090

## LED Driver with Square-Law Dimming Control

### FEATURES

- Emulates incandescent lamp 'Square Law' luminance curve.
- LED dimming controlled by Pulse Width Modulation ranging from 50HZ to 200HZ.
- Maximum LED current adjustable from 10mA to 20mA.
- 200:1 Dimming Range at 50Hz. 40:1 Dimming Range at 200Hz
- Drives 8 LED outputs with matched current drive.
- Drivers can be cascaded to synchronously drive additional LEDs.
- Plastic 16 lead SOIC package.

### APPLICATIONS

- LED replacement for dimmable incandescent lamps.
- Avionics instrument and panel lighting.
- Balanced display and keyboard backlighting.

### GENERAL DESCRIPTION

DEI1090 device is a 16 pin bipolar integrated circuit designed to drive eight LEDs and provide Pulse Width Modulated (PWM) dimming control according to the luminance curve of incandescent lamps. All eight LEDx pins are driven with an average current proportional to the square of the input dimming voltage to control the LED brightness. Drivers can be cascaded to synchronously drive additional LED groups. The dimming control input may be a DC or AC voltage.

**Table 1 - Pin Description**

PIN	NAME	DESCRIPTION
1	VDD	POWER INPUT. +4.5 to +16.5 VDC.
2	VIN	ANALOG INPUT. 0 to 2.5V AC or DC analog input for brightness control.
3	FILT	ANALOG IO. Optional external filter resistor and capacitor used when 400HZ AC control signals are supported. This pin must be connected to ground through a resistor even in DC applications.
4-6,9,11-14	LED1-8	LED DRIVE OUTPUT. LED cathode connection. LED average current is proportional to the square of VIN.
7	FSET	ANALOG INPUT. External capacitor input to set PWM frequency.
8	GND	POWER INPUT. Ground.
10	ISET	ANALOG INPUT. External resistor input to set LED current.
15	PWM	ANALOG OUTPUT. PWM output drives multiple 1090 slave devices for synchronous operation.
16	ENABLE	LOGIC INPUT. HIGH enables operation. LOW sets all LED outputs OFF and sets standby state.

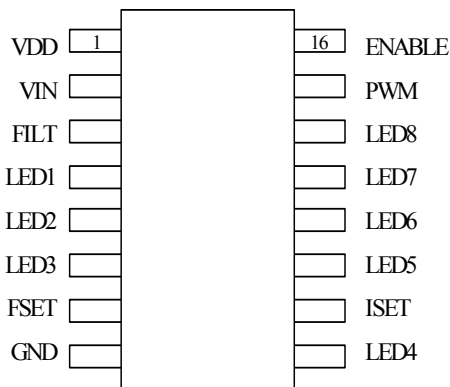

## FUNCTIONAL DESCRIPTION

### Top Level

Figure 1 is the top level diagram of the DEI1090 Square Law LED Dimmer. The input voltage from a dimming bus is scaled at the VIN control pin to a range between 0 and 2.5V. The load on the dimming bus is kept to a minimum since the DEI1090 is locally powered through the VDD pin.

A peak detector/filter is provided to allow use of either a DC or AC control input. The optional filter is set by an external resistor and capacitor at the FILT pin. **A resistor load must be used even in DC applications. (Recommended 100kΩ)**

The ENABLE pin enables the part when high and must be tied to VDD when not used. When the ENABLE pin is low, the part is put into a standby state and all LEDs are set to off.

Eight LED driver outputs are provided. Each is driven with a Pulse Width Modulated (PWM) current waveform that has an average current proportional to the square of the voltage at the VIN pin. The PWM frequency is set with an external capacitor at the FSET pin. The peak LED current at 100% duty cycle is a multiple of the Iset current which is set with an external resistor at the ISET pin.

The PWM pin is provided to allow cascading multiple DEI1090s to expand the number of synchronously controlled LED driver output.

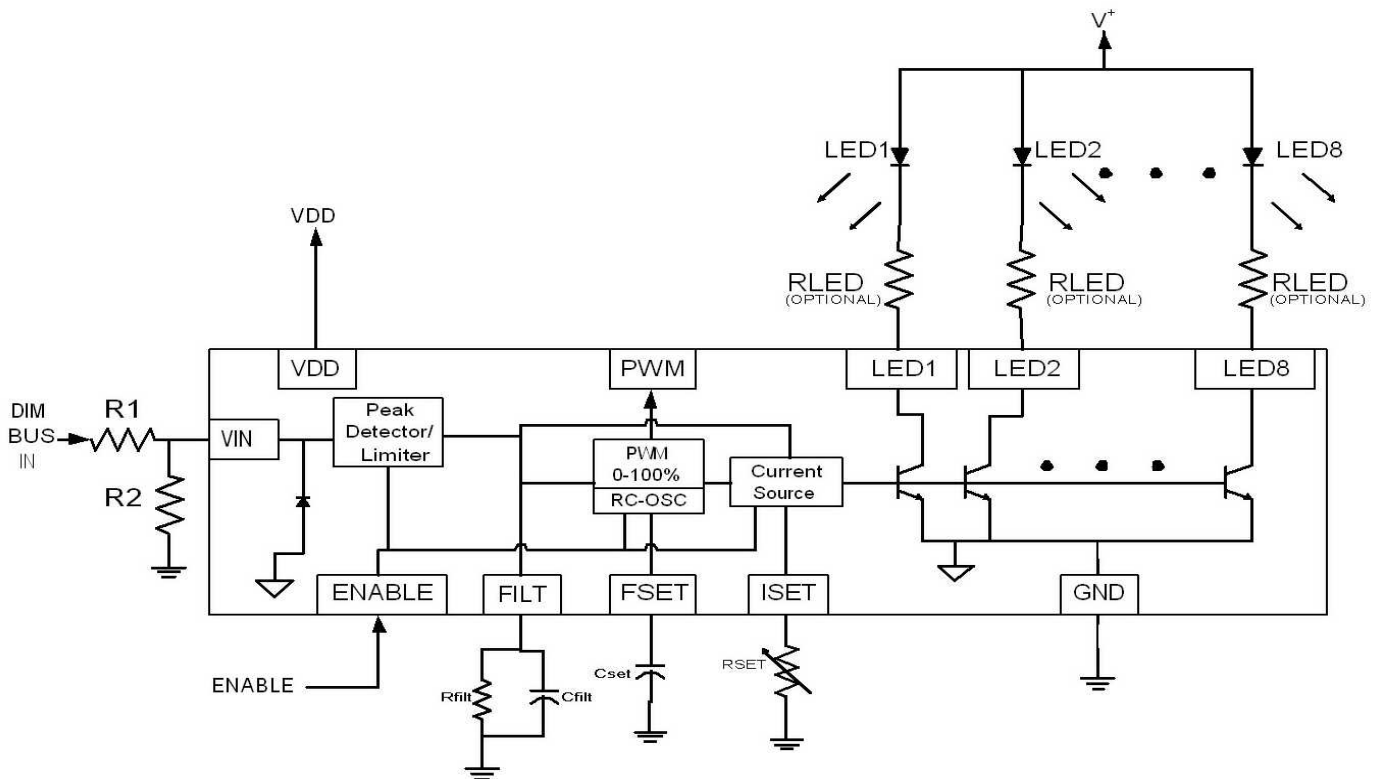

Figure 1 - DEI1090 Simplified Block Diagram

### Input Filter and Peak Detector

An external resistor divider is used to scale the voltage applied to the VIN pin providing interface to a variety of standard avionics dimming bus formats i.e. 0-5VDC, 0-5VAC, 0-28VDC as showing in Table . The VIN interface contains a peak detector and a filter circuit to allow 400HZ AC control input signals. The external filter connections are shown in Figure 1. When an AC input is used, Rfilt and Cfilt should be set up to filter 400 Hz into DC. The signal to the FILT pin is limited to an internal 2.5V reference. **A resistor load (Rfilt in the figure) must be used for the FILT pin even in DC applications.**

## Dimming Control

The DEI1090 VIN control signal ranges from 0V to 2.5V full scale. This controls the PWM duty cycle and the LED current to produce an average current proportional to the square of the control voltage. The square-law characteristic equations are shown below and the resulting LED average current vs. VIN curve is shown in Figure 2.

The square-law curve includes a 0.5V typical onset voltage ( $V_{os}$ ) where LED illumination begins. When VIN is below  $V_{os}$ , the LEDs are off ( $I_{led} < I_{off}$ ) which emulates the behavior of an incandescent lamp. The current gain ( $I_{gain}$ ) from the ISET pin to the LEDx output pins is typically around 24 for a 5V system.

$$I_{led}(peak) = \begin{cases} 0 & \text{if } V_{in} < V_{os} \\ \left[ \frac{(V_{in} - V_{os})}{R_{set}} \right] * I_{gain} & \text{if } V_{in} > V_{os} \text{ and } < 2.5V \\ \left[ \frac{(2.5V - V_{os})}{R_{set}} \right] * I_{gain} & \text{if } V_{in} > 2.5V \end{cases}$$

$$I_{led}(duty\ cycle) = \begin{cases} 0\% & \text{if } V_{in} < V_{os} \\ \frac{(V_{in} - V_{os})}{(2.5V - V_{os})} & \text{if } V_{in} > V_{os} \text{ and } < 2.5V \\ 100\% & \text{if } V_{in} > 2.5V \end{cases}$$

$$I_{avg} = \begin{cases} 0 & \text{if } V_{in} < V_{os} \\ \left[ \frac{(V_{in} - V_{os})^2}{(2.5V - V_{os}) * R_{set}} \right] * I_{gain} & \text{if } V_{in} > V_{os} \text{ and } < 2.5V \\ \left[ \frac{(2.5V - V_{os})}{R_{set}} \right] * I_{gain} & \text{if } V_{in} > 2.5V \end{cases}$$

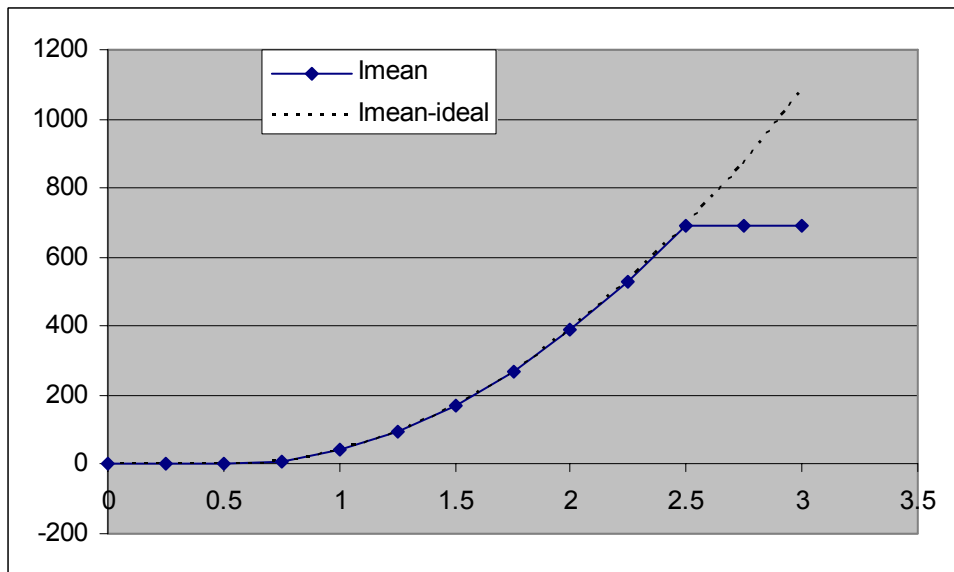

Figure 2 - Square-Law Relationship of VIN vs. Iled Average

## APPLICATION INFORMATION

### Setting PWM Frequency

The PWM frequency can be set with an external capacitor ( $C_{fset}$ ) as shown in Figure 1. The PWM frequency is determined by:

$$PWM \text{ frequency} = \frac{I_{fset}}{2 * C_{fset}}; \text{ where } C_{fset} \text{ is in } \mu\text{F} \text{ and } I_{fset} \text{ is in } \mu\text{A}$$

For example, to set the frequency to 120Hz nominal with a 12  $\mu\text{A}$  charging current,  $C_{fset}$  should be 0.05  $\mu\text{F}$ . The serrodyne waveform will be seen at the FSET pin and is buffered to the PWM output. In most cases the actual frequency will be slightly lower since the reset of the serrodyne (ramp generator) is not instantaneous.

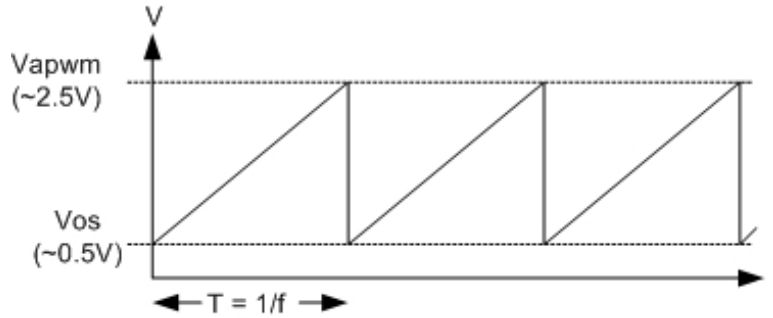

Figure 3 - PWM Serrodyne Waveform

### Cascading Multiple Drivers

Multiple drivers can be cascaded by connecting the PWM pin to the FSET pin of one slave device. If more than two are required, daisy chain the next PWM to the next FSET pin. The PWM output waveform is a buffered Serrodyne signal as generated at the FSET pin.

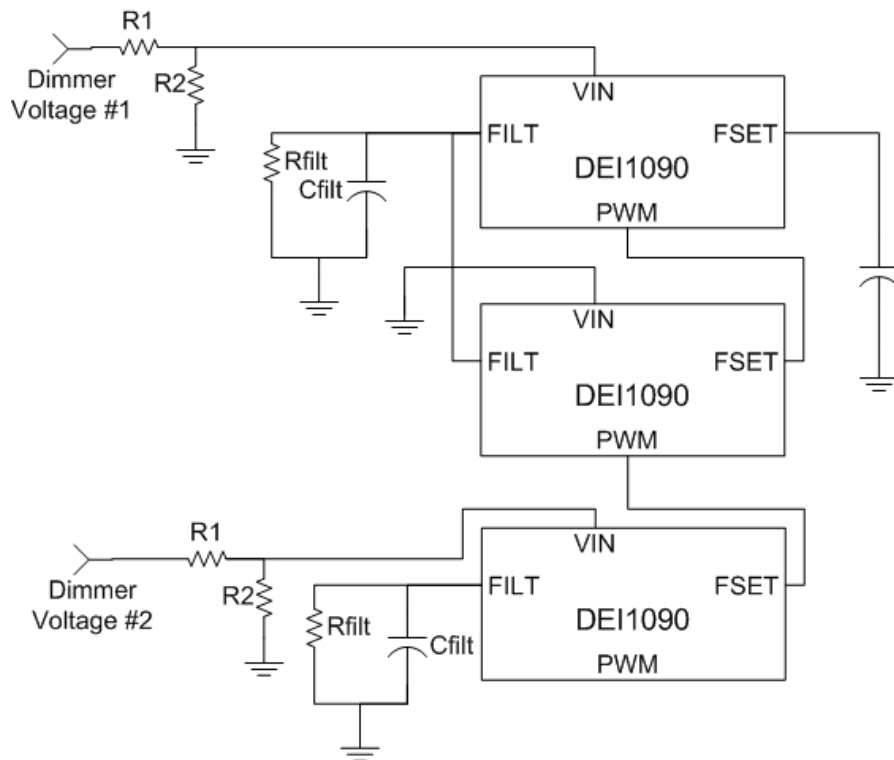

Figure 4 - Cascading Multiple Drivers

## Setting Up Your Input and Filter

Many dimmer applications use a 400 Hz AC source for the dimming voltage. The brightness of the incandescent lamp is proportional to the RMS value of the AC signal. As an added feature, the DEI1090 has an input peak detector and allows for an external filter to be added so that AC dimming signals can be used to create a proportional DC voltage. The input is also limited at this stage to an on-chip 2.5V reference value.

All applications require an input divider to bring the signal to a level that is suitable for the DEI1090 device. After the input is half wave rectified and peak detected, then it is sent to the FILT pin where a filter should be placed to remove ripple from the signal. The input resistors R1 and R2 shown in Figure 5 should be set up as shown in Table 2.

Input Type	R1	R2	Comments
5V AC Dimming Voltage	$1.83 * R$	R	R should be at least 10K ohms to protect the chip from clamp current when an AC signal is used.
5V DC Dimming Voltage	R	R	
28V DC Dimming Voltage	$10.2 * R$	R	

**Table 2 - Resistor Ratios for Scaling Dimmer Voltages**

## Example of Rset Determination

Rset is selected to set the peak current value at 100% duty cycle. A fixed resistor or trimmer may be used to set the LED current for the required luminance at full scale Vin. The peak LED current range is from 10 mA and 20 mA. Resistor values should be set as shown in Table 3.

Note: To measure or adjust the peak current, drive Vin > 2.5V and < VDD.

\* - Iled max in the table assumes a gain of 24.

Rset	Iset max	Iled max *
4.80 kΩ	417 uA	10 mA
4.00 kΩ	500 uA	12 mA
3.43 kΩ	583 uA	14 mA
3.00 kΩ	667 uA	16 mA
2.67 kΩ	749 uA	18 mA
2.40 kΩ	833 uA	20 mA

**Table 3 - Rset versus LED Maximum Current**

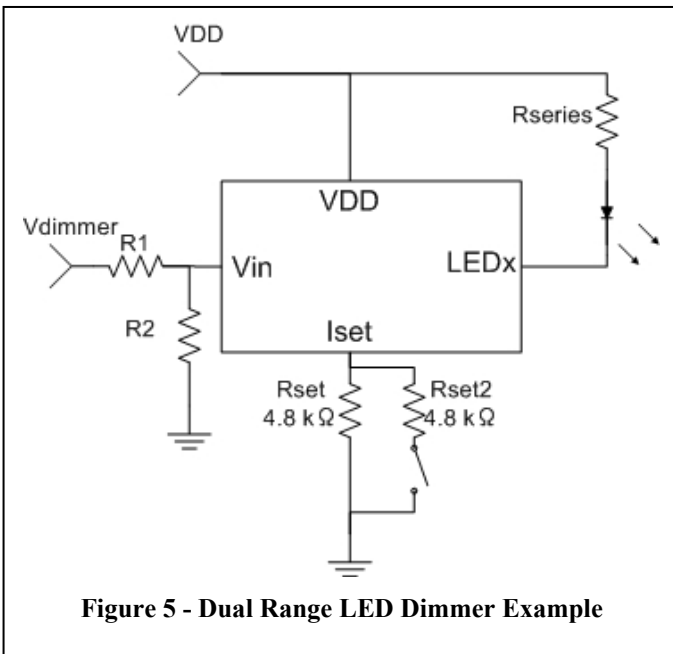

**Figure 5 - Dual Range LED Dimmer Example**

## Creating a Dual Range Dimmer

To create a dual range dimmer with two dimming curves, the circuit can be set up to switch a second Rset resistor in parallel with the primary Rset resistor.

An example is shown in Figure 5. This uses Rset = 4.8 kΩ resistor in parallel with Rset2 = 4.8 kΩ resistor and a switch. When the switch is open, Rset = 4.8 kΩ and the maximum LED current is ~ 10 mA. When the switch is closed, the equivalent resistance of 2.4 kΩ creates a maximum peak current of ~ 20 mA.

Note: To measure the peak current, drive Vin > 2.5V and < VDD.

## LED Output Compliance Voltage and Power Consumption

The DEI1090 regulates current through eight LED outputs. Each LEDx output can regulate LED current over a wide compliance voltage range. The voltage at the LED pin should be designed to be as low as possible to minimize power dissipation in the IC. Figure 6 shows typical LED output I-V characteristics for various Iset values.

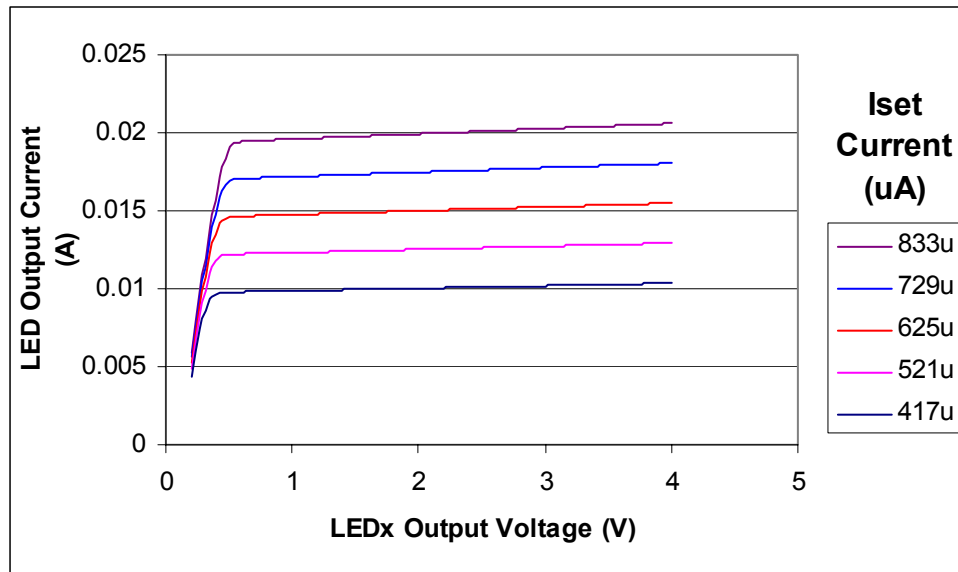

Figure 6 – Output I-V Characteristics

As is shown in Figure 6, an output voltage above 0.7V will regulate the output current.

Example calculation of IC power dissipation. Use Figure 1:

Given that the voltage across the LED is 2V and the current through each LED is 20 mA and there is 1 LED per output, Vdd supply is +12V, V+ is +5v and Iq (VDD quiescent current, see Table 6) is 3.5ma and the optional RLED resistors aren't being used, the average IC power dissipation due to the LED drive is:

$$P_d = P_q + P_{ld} = I_q * V_{dd} + 8 * I_{out} * V_{out} = 3.5\text{mA} * 12\text{v} + 8 * 20\text{ mA} * (5\text{v}-2\text{v}) = 42\text{mw} + 480\text{mw} = 522\text{mw}$$

Pd must be kept below the maximum power listed in Table 4 to keep the junction temperature < Tjmax. Pd should be minimized for optimum IC reliability.

Assuming a Theta-ja (junction to ambient rise with power) of 74C/W, the junction temperature is .522 x 74 = 38.6C above ambient temperature.

One way to control the IC power dissipation is to place a resistor in series with the LED as shown in Figure 1. This will drop the excess V+ voltage in the resistor rather than in the IC.

### Voltage Dependency of Igain

The gain from Iset to Iled is nominally about 24. This gain has a supply voltage dependency so that the gain at VDD = 15V is higher than the gain when VDD = 5V. The minimum and maximum gain values for some common operating voltages are listed in Table 6. An example waveform of the linear voltage dependency is shown in Figure 7. **Note:** All LED outputs of the IC should be loaded. The part will still work with outputs

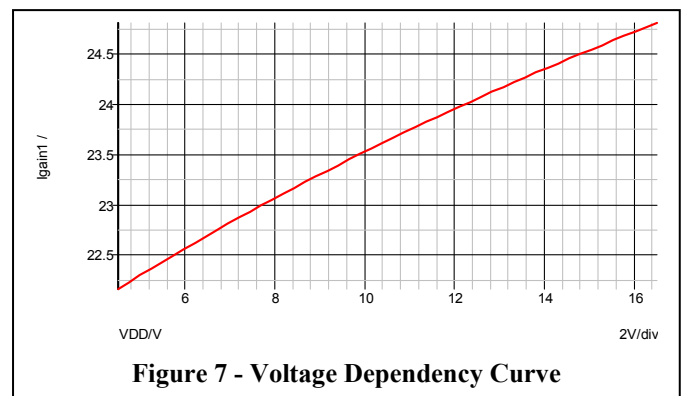

Figure 7 - Voltage Dependency Curve

unloaded but the current calculation may be skewed. For example, if four LED's are to be run at 20ma each, the Iset should be set to 10ma and the LED's paralleled in groups of two in order to use up all eight outputs.

### Adjusting Onset Voltage

The LED onset voltage (Vos) is used to match the turn-on voltage of an incandescent lamp. If an application requires a Vos lower than the 0.5V Vos of the IC, an offset voltage may be added to the Vin input making the apparent turn-on voltage lower. As shown in Figure 8, the VDD is added in through Ros which is a much higher value than R1 and R2.

As an example :

Vos is typically 0.5V

Choose R1 = R2 = 10 kΩ (5V DC Dimming Voltage)

If an onset voltage of 0.25 V is desired then, using the equation:

$$V_{in} = V_{dimmer} * \frac{R2 \parallel R_{os}}{R1 + (R2 \parallel R_{os})} + VDD * \frac{R1 \parallel R2}{R_{os} + (R1 \parallel R2)}$$

Use Ros = 100 kΩ, then  $V_{in} \cong V_{dimmer} * \frac{1}{2} + VDD * 0.05$ .

This results in about an extra 0.25 V for a 5V supply and an apparent 0.25V onset voltage from the dimming bus. This onset voltage will vary with VDD.

### Slew Rate Control

The current through the LED can be limited when required. A 10uS rise and fall time would require a minimum 50 mH inductor in series with the set resistor on the ground side. Place a diode in parallel with the inductor from ground to the top pin in order to clamp negative going pulses to one diode drop below ground.

## ELECTRICAL DESCRIPTION

Table 4 - Absolute Maximum Ratings

PARAMETER (Voltages referenced to Ground)	MIN	MAX	UNITS
VDD Supply Voltage		+20	V
Storage Temperature	-65	+150	°C
Input Voltage			
FSET, ISET, ENABLE, PWM pins	- 0.3	VDD+0.3	V
VIN pin (during AC dimmer operation, keep absolute current below 1 mA)	- 0.6	VDD+0.3	V
LED1-8 pins	- 0.3	20	V
Input Current: Any pin	-20	20	mA
Power Dissipation @ 85 °C: (> 10 Sec)			
16 Lead SOIC		700	mW
ESD per JEDEC A114-A Human Body Model		2000	V
Peak Body Temperature,			°C
Non-G Package	-	240	
- G Package		260	

**Notes:** Stresses above absolute maximum ratings may cause permanent damage to the device.

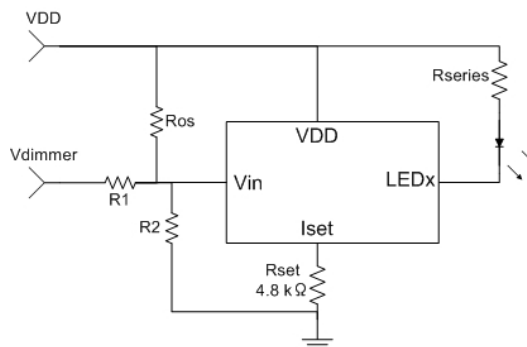

Figure 8 - Vos Adjustment

**Table 5 - Recommended Operating Conditions**

PARAMETER (Voltages referenced to Ground)	MIN	MAX	UNITS
VDD Supply Voltage	+4.5	+16.5	V
Operating Temperature Plastic Package	-55	+85	°C
Junction Temperature: Tjmax, Plastic Packages (Limited by molding compound Tg)		125	°C

**Table 6 - Electrical Characteristics**

Conditions: Temperature: -55°C to +85°C for plastic, VDD = 4.5 to 16.5V Unless otherwise noted.												
PARAMETER	CONDITIONS	SYMBOL	-55°C (4)			25°C (4) (or over temp range)			85°C (4)			UNITS (1)
			MIN	NOM	MAX	MIN	NOM	MAX	MIN	NOM	MAX	
<b>SUPPLY CURRENT</b>												
VDD Standby Current	ENABLE = 0.0 V, VDD=16.5V	Istdby		8	50		6	15		30	100	uA
VDD Quiescent Current	ENABLE=VDD= 16.5V; VIN = 0.0 V; All LEDs off	Iq		2.5	5		3.25	5		3.5	5	mA
<b>PULSE WIDTH MODULATOR</b>												
VIN at 100% PWM Duty Cycle		VAPWM				2.4	2.45	2.5				V
VIN at PWM Onset Voltage		Vos1				0.4	0.5	0.6				V
FSET charge current	FSET = 0V	IFSET	11	13.3	15	13	15	16	13	14.2	16	µA
PWM Output Voltage Accuracy from FSET Voltage	Cascaded DEI1090	PWMacc				-3	0.3	3				%
<b>VIN BUFFER/PEAK DETECTOR/ FILTER</b>												
VIN Input Voltage Range		VIN				0		2.5				V
VIN Input Current	VIN = 0V to 2.5V	Iin				-10	-5					uA
Input Buffer Accuracy (DC)	VIN/Vfilt VIN = 1.0v	BufAcc				-3	0.5	3				%
FILT Output Voltage	VIN = 0 to 2.5V	VFILT				0		2.5				V
<b>LOGIC INPUT</b>												
ENABLE Input Low		Vil			0.4			0.4			0.4	V
ENABLE Input High		Vih	2.4			2.4			2.4			V
ENABLE Input Current Low	ENABLE = Vilmax	Iil				-5	-1.8					uA

**Conditions:** Temperature: -55°C to +85°C for plastic, VDD = 4.5 to 16.5V Unless otherwise noted.

PARAMETER	CONDITIONS	SYMBOL	-55°C (4)			25°C (4) <i>(or over temp range)</i>			85°C (4)			UNITS (1)
			MIN	NOM	MAX	MIN	NOM	MAX	MIN	NOM	MAX	
ENABLE Input Current Hi	ENABLE = Vihmin	Iih				-5	-1.75					uA
<b>LED DRIVER</b>												
ISET Bias Voltage @ 100% Duty Cycle	VIN = 2.5V	VSET					2.0					V
LED Output Minimum Compliance Voltage (5)	ILED = 20mA	VCOMP				0.7						V
LED Output Off State Leakage Current	VIN = 0V, LEDx = 5V	I <sub>OFF</sub>					0.01 0	0.05				μA
Pin-to-PIN LED Output current matching, relative to median	VDD = 5V, 12V, 15V (3)	I <sub>MATCH</sub>			±6			±5			±4	%
Current Gain: Iset = 400uA	VDD = 5V (3)	I <sub>LED5L</sub>	9		14	9		13	7		11	mA
	VDD = 12V (3)	I <sub>LED12L</sub>	12		17	11		16	8		11	mA
	VDD = 15V (3)	I <sub>LED15L</sub>	12		17	12		16	8		12	mA
Current Gain: Iset = 800uA	VDD = 5V (3)	I <sub>LED5H</sub>	15		21	16		20	14		18	mA
	VDD = 12V (3)	I <sub>LED12H</sub>	19		26	17		23	16		20	mA
	VDD = 15V (3)	I <sub>LED15H</sub>	20		27	17		23	16		20	mA

**Notes:**

1. Currents flowing into the device are positive. Currents flowing out of the device are negative. Voltages are referenced to ground.
2. Guaranteed by design. Not production tested.
3. LEDx = 1V, VIN = 2.5V, FSET = 0.5V
4. If no -55C or 85C limits are stated, 25C limits apply at all temperatures.
5. Guaranteed by design.

# PACKAGE DESCRIPTION

## 16 Lead WB SOIC, Non-G Package

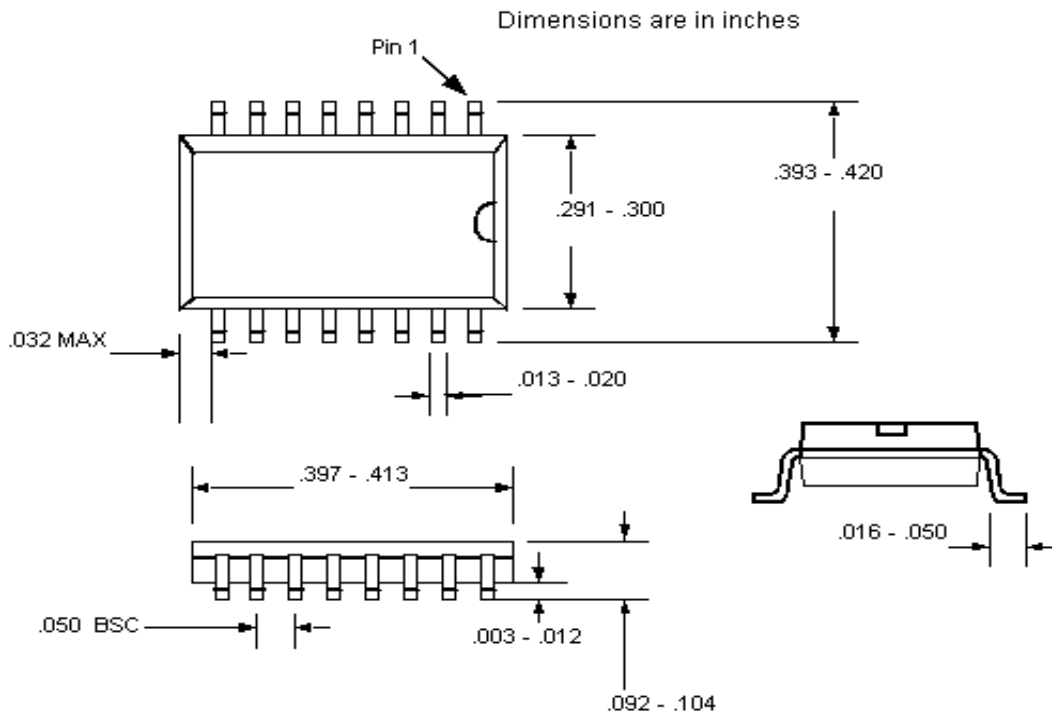

**Table 7 - 16 Lead WB SOIC Characteristics**

PACKAGE TYPE	16 Lead WB SOIC	16 Lead WB SOIC - G
REFERENCE	16 Lead WB SOIC	16 Lead WB SOIC - G
<b>THERMAL RESISTANCE:</b>		
$\theta_{JA}$ (4 layer PCB with Power Planes)	74 °C/W	74 °C/W
$\theta_{JC}$	24 °C/W	24 °C/W
JEDEC MOISTURE SENSITIVITY LEVEL (MSL)	MSL 2 / 240°C	MSL 1 / 260°C
LEAD FINISH MATERIAL / JEDEC Pb-free CODE	SnPb	NiPdAu e4
Pb-Free DESIGNATION	Not Pb-free	RoHS Compliant
JEDEC REFERENCE	MO-153-AC	MO-153-AC

## 16 Lead WB SOIC, -G Package

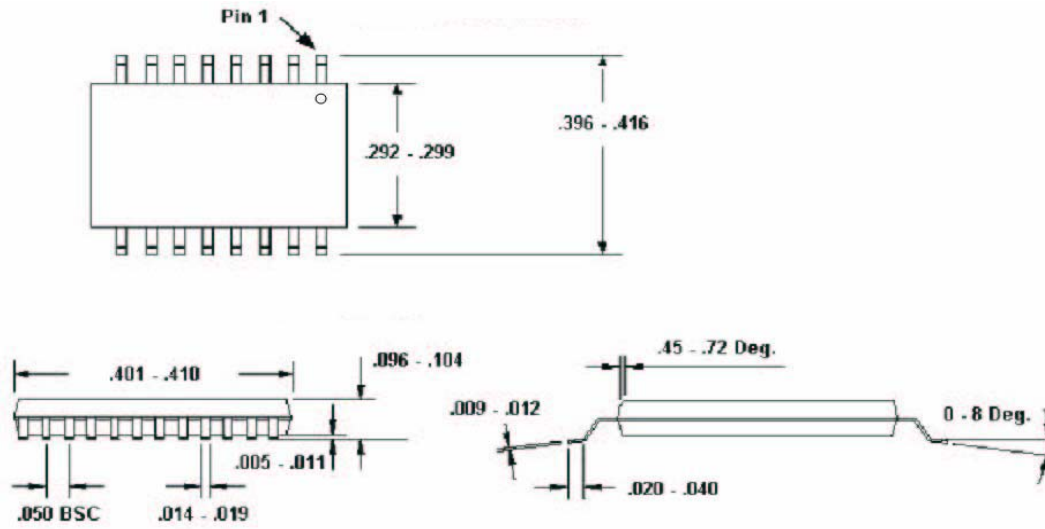

## ORDERING INFORMATION

Part Number	Marking	Package	Temperature
DEI1090-SES	DEI1090	16 WB SOIC	-55 °C to +85 °C
DEI1090-SES - G	DEI1090 E4	16 WB SOIC	-55 °C to +85 °C

DEI reserves the right to make changes to any products or specifications herein. DEI makes no warranty, representation, or guarantee regarding suitability of its products for any particular purpose.