

**DEVICE
ENGINEERING
INCORPORATED**

385 East Alamo Drive
Chandler, AZ 85225
Phone: (480) 303-0822
Fax: (480) 303-0824
E-mail: admin@deiaz.com

DEI1066

OCTAL GND/OPEN INPUT, SERIAL OUTPUT INTERFACE IC

FEATURES

- Eight GND/OPEN discrete inputs
 - Meet electrical requirements for ABD0100 GND/OPEN discrete input.
 - Hysteresis provides noise immunity
 - Internal pull up resistor with 1mA source current to prevent dry relay contacts.
 - Internal isolation diode
 - Inputs protected from Lightning Induced Transients per DO160D, Section 22, Cat A3 and B3.
- 3-wire serial interface (/CS, CLK, DO)
 - Direct interface to Serial Peripheral Interface (SPI) port.
 - TTL/CMOS compatible inputs and Tristate output
 - 10MHz Data Rate
 - Serial input to expand Shift Register
- Logic Supply Voltage (VCC): 3.3V or 5V
- Analog Supply Voltage (VDD): 5V to 18V
- 16L NB SOIC package
- 16L Ceramic SO Package

PIN ASSIGNMENTS

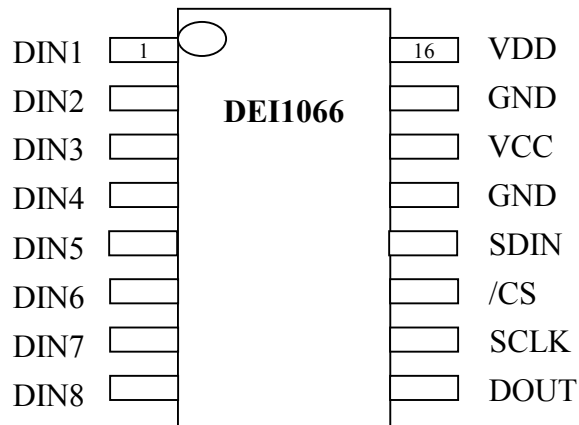

Figure 1 DEI1066 Pin Assignment (16 Lead NB SOIC)

FUNCTIONAL DESCRIPTION

The DEI1066 is an eight-channel discrete-to digital interface BICMOS device. It senses eight Ground/Open discrete signals of the type commonly found in avionic systems. The data is read from the device via an eight-bit serial shift register with 3-state output. This serial interface is compatible with the industry standard Serial Peripheral Interface (SPI) bus.

Table 1 Pin Descriptions

Pins	Name	Description
8-1	DIN[8:1]	Parallel data inputs. Eight Ground/Open format discrete signals. These have an internal pull-up to VDD. The logic threshold and hysteresis characteristics are determined by the applied VDD voltage.
9	DOUT	Serial data output. This pin is the output from the last stage of the shift register. This is a 3-state output.
10	SCLK	Serial Shift Clock. A low-to-high transition on this input shifts data on the serial data input into the shift register and data in stage 8 is shifted out DOUT, being replaced by the data previously stored in stage 7.
11	/CS	Chip Select. A high-to-low transition on this input loads data from the parallel DIN[8:1] inputs into the shift register. A low level on this input enables the DOUT 3-state output and the shift register. A high level on this input forces DOUT to the high impedance state and disables the shift register so SCLK transitions have no effect.
12	SDIN	Serial Data Input. Data on this input is shifted into the shift register on the rising edge of the SCLK input if the /CS input is low. This input has an internal pull-down resistor to GND.
13	GND	Logic Ground.
14	VCC	Logic Supply Voltage.
15	GND	Analog Ground.
16	VDD	Analog Supply Voltage.

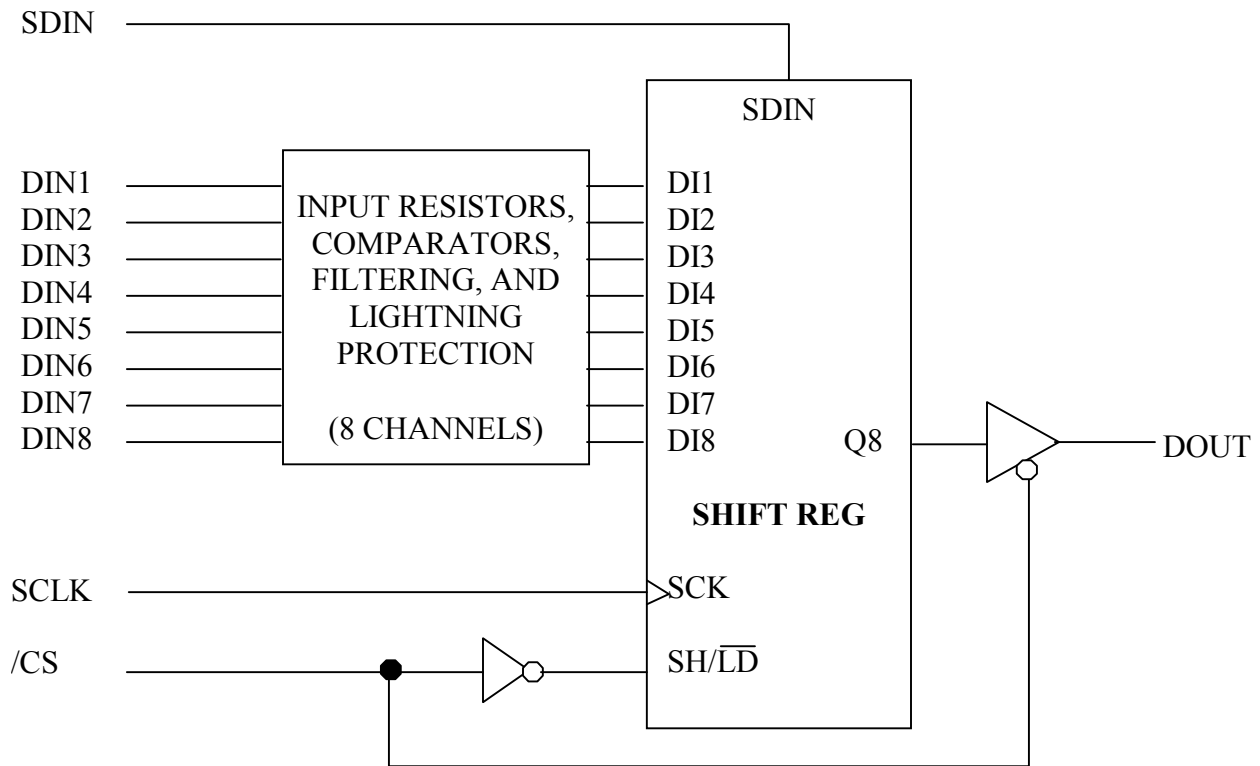

Figure 2 DEI1066 LOGIC DIAGRAM

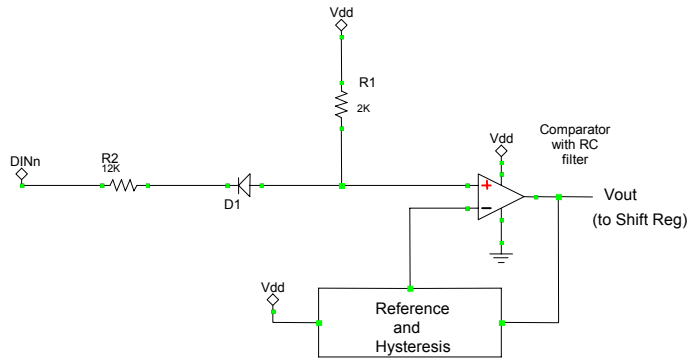

Figure 3 DINn Input Circuit

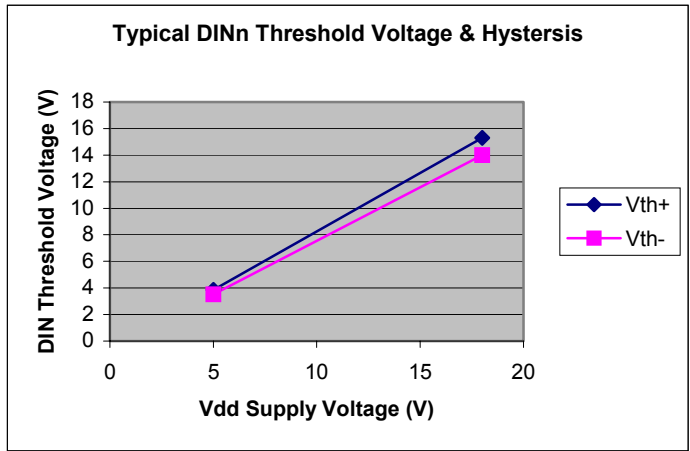

Figure 4 DIN Threshold vs Vdd

Table 2 Truth Table

/CS	SCLK	SDIN	DIN[8:1]	SREG Q1	DOUT
1	X	X	X	X	HI-Z
↓	X	X	Sampled into Shift Register	DIN1	Enabled DIN8
0	↑	0	X	0	SREG Q8
0	↑	1	X	1	SREG Q8
0	↓	X	X	No Change	No Change
↑	X	X	X	No Change	Disabled to HI-Z

DIN[8:1] Input Structure

Each of the eight discrete inputs consist of the circuit shown in Figure 3. Each DINn signal is conditioned by the resistor / diode network and presented to the comparator IN+. The reference and hysteresis voltage is developed at the comparator IN-. Some notable features are:

- When Vdd is +15V, the circuit shall source >1mA to a grounded input. This current will prevent a “dry” relay contact.
- The input threshold voltage and hysteresis varies with the Vdd supply.
 - For Vdd of +5V, the falling Vth > 3.5V.
 - For Vdd of +15V, the rising Vth < 14V.
 - For Vdd of +18V, the rising Vth < 15.4V.
 - Hysteresis is approximately as shown in Figure 4.
 - The input thresholds vary with Vdd supply voltages and can be approximated as follows:
For Vdd = 5V to 18V
 - $V_{lh_max} = 0.98 * V_{dd} - 0.65V$
 - $V_{hl_min} = 0.95 * V_{dd} - 0.8V$
- The comparator includes an RC filter to provide noise rejection of transient pulses of up to several uS. Thus there is a relatively large DINx setup time of several uS (Refer to timing parameter tsu2).
- The inputs can withstand continuous input voltages of 40V minimum. The isolation diode breakdown voltage is greater than 50V. The 12K Ohm input resistor is designed to limit diode breakdown current to safe levels during transient events.

Serial Interface and Shift Register

The DE11066 digital interface is an 8-Bit Serial or Parallel-Input / Serial-Output Shift Register with 3-State Output. The control inputs to the shift register are connected as shown in Figure 2 DE11066 LOGIC DIAGRAM to implement an SPI compatible bus consisting of /CS, SCLK, DOUT, and SDIN. The Figure 5 waveform depicts a typical 8-Bit read cycle where the 8 DIN signals are read on to the serial bus. The Figure 6 waveform demonstrates a daisy-chain application where a 16-Bit read cycle includes the serial data passed through from the SDIN input.

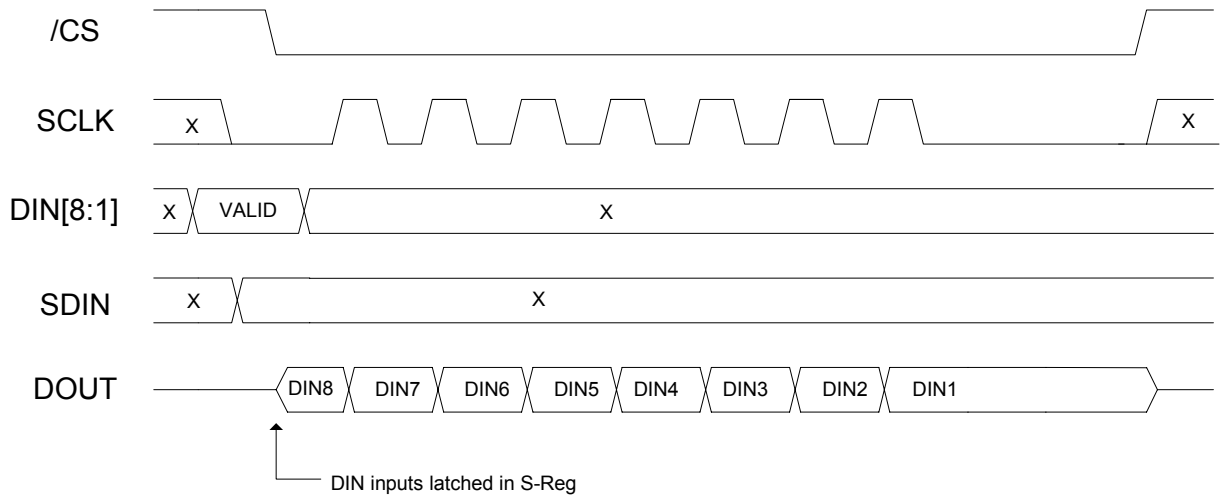

Figure 5 Serial Bus Read Cycle, 8 Bit

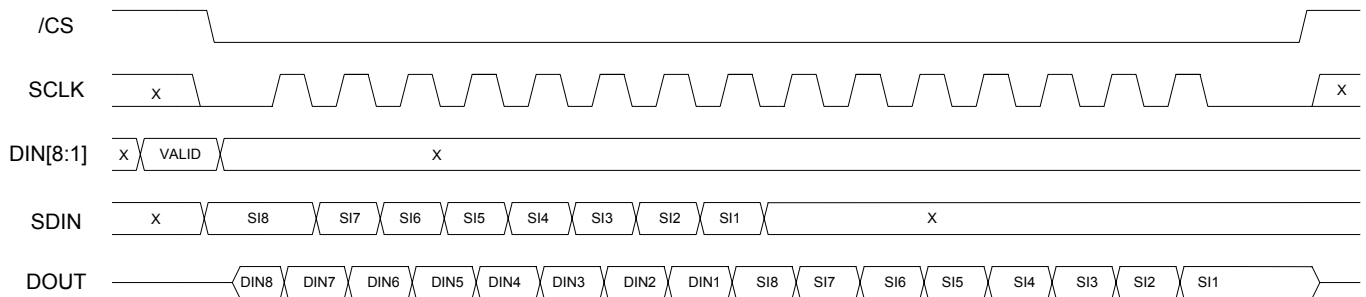

Figure 6 Serial Bus Read Cycle, 16 Bit Daisy Chain

Lightning Protection

DINn inputs are designed to survive lightning induced transients as defined by RTCA DO160D, Section 22, Cat A3 and B3, Waveforms 3, 4, and 5A, Level 3. See waveforms below.

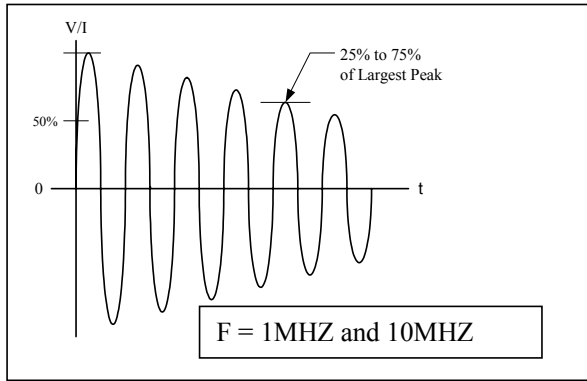

Figure 7 Voltage / Current Waveform 3

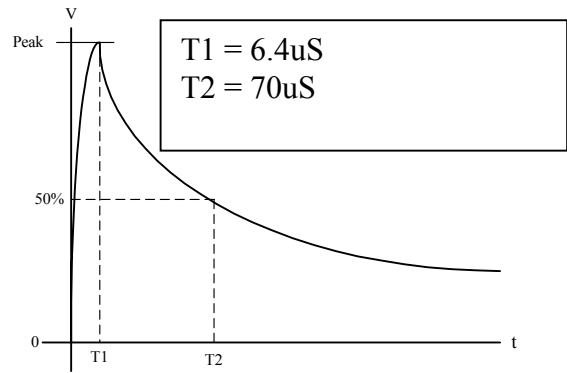

Figure 8 Voltage Waveform 4

Waveform Source Impedance characteristics:

- Waveform 3 $V_{oc}/I_{sc} = 600V / 24A \Rightarrow 25 \text{ Ohms}$
- Waveform 4 $V_{oc}/I_{sc} = 300V / 60A \Rightarrow 5 \text{ Ohms}$
- Waveform 5A $V_{oc} / I_{sc} = 300V / 300A \Rightarrow 1 \text{ Ohm}$

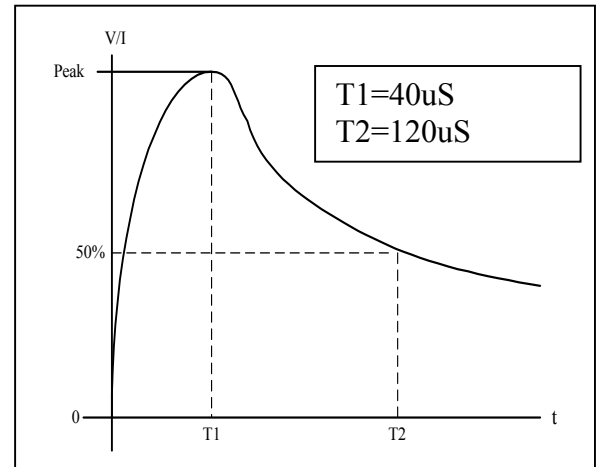

Figure 9 Current/Voltage Waveform 5A

ELECTRICAL DESCRIPTION

Table 3 Absolute Maximum Ratings

PARAMETER	MIN	MAX	UNITS
Vcc Supply Voltage	-0.3	+7.0	V
Vdd Supply Voltage	-0.3	20	V
Operating Temperature			
Plastic Packages	-55	+85	°C
Ceramic Packages	-55	+125	
Storage Temperature			
Plastic Packages	-55	+150	°C
Ceramic Packages	-65	+150	
Input Voltage			
DIN[8:1] Continuous	-5	+40	V
DO160D, Waveform 3, Level 3	-600	+600	V
DO160D, Waveform 4 and 5, Level 3	-300	+300	V
Logic Inputs	-1.5	VCC + 1.5	V
DOUT	-0.5	VCC + 0.5	v
Power Dissipation @ 85 °C: (> 10 Sec)			
16 Lead SOIC		0.8	W
16 Lead CSOP		0.53	W
Junction Temperature:			
Tjmax, Plastic Packages		145	°C
Tjmax, Ceramic Packages		150	°C
ESD per JEDEC A114-A Human Body Model			
Logic and Supply pins		2000	V
DIN pins		1000	
Lead Soldering Temperature (10 sec duration)		280	°C
Notes:			
1. Stresses above absolute maximum ratings may cause permanent damage to the device.			
2. Voltages referenced to Ground			

Table 4 Recommended Operating Conditions

PARAMETER	SYMBOL	CONDITIONS
Supply Voltage	VCC VDD	5.0V±10%, 3.3V±10% 5.0 to 18V
Logic Inputs and Outputs		0 to VCC
Discrete Inputs	DIN[8:1]	0 to 40V
Operating Temperature		
Plastic		-55 to +85 °C
Ceramic		-55 to +125 °C

Table 5 DC Electrical Characteristics

SYMBOL	PARAMETER	TEST CONDITIONS	VCC (V)	LIMITS		UNIT
				-55 to +85°C	-55 to +125°C	
LOGIC INPUTS AND OUTPUTS VDD = +5V to +18V						
V _{IH}	Min hi level input voltage		3.0	2.0	2.0	V
			4.5	2.0	2.0	
			5.5	2.0	2.0	
V _{IL}	Max lo level input voltage		3.0	0.8	0.8	V
			4.5	0.8	0.8	
			5.5	0.8	0.8	
V _{Ihst}	Min input hysteresis voltage, SCLK input	(1)	3.0 4.5 5.5	50	50	mV
V _{OH}	Min hi level output voltage	I _{OUT} < 20uA	3.0 4.5 5.5	VCC - 0.1	VCC - 0.1	V
		I _{OUT} < 4.5mA	4.5 5.5	3.2 4.5	3.0 4.3	V
V _{OL}	Max low level output voltage	I _{OUT} < 20uA	3.0 4.5 5.5	0.1 0.1 0.1	0.1 0.1 0.1	V
		I _{OUT} < 4.5mA	4.5 5.5	0.33 0.33	0.40 0.40	V
I _{IN}	Max input leakage Logic inputs except SDIN. SDIN	Vin = Vcc or GND	5.5 5.5	±1.0 ±750	±2.0 ±750	uA
I _{OZ}	Max 3-state leakage current	Output in Hi Impedance state.	5.5	±5.0	±10.0	uA
DISCRETE INPUTS VDD = +18V						
V _{IH}	Min HI level input voltage		3.0 to 5.5	15.7	15.9	V
V _{IL}	Max LO level input voltage		3.0 to 5.5	14.2	14.2	V
V _{Ihst}	Min input hysteresis voltage		3.0 to 5.5	1.0	1.0	V
I _{IH}	Max hi level input current	Vin = 18V Vin = 40V	3.0 to 5.5	5 20	10 40	uA
I _{ILmax}	Max lo level input current	Vin = 0V	3.0 to 5.5	-1.6	-1.6	mA
I _{ILmin}	Min lo level input current	Vin = 0V	3.0 to 5.5	-1.0	-1.0	mA
DISCRETE INPUTS VDD = +5V						
V _{IH}	Min HI level input voltage		3.0 to 5.5	4.35	4.35	V
V _{IL}	Max LO level input voltage		3.0 to 5.5	3.53	3.53	V
V _{Ihst}	Min input hysteresis voltage		3.0 to 5.5	0.33	0.33	V
I _{IH}	Max hi level input current	Vin = 18V Vin = 40V	3.0 to 5.5	5 20	10 40	uA
I _{ILmax}	Max lo level input current	Vin = 0V	3.0 to 5.5	-0.5	-0.5	mA
I _{ILmin}	Min lo level input current	Vin = 0V	3.0 to 5.5	-0.25	-0.25	mA
SUPPLY VOLTAGES VDD = +15V						
ICC	Max quiescent logic supply current	Vin(logic) = Vcc or GND VIN[8:1] = open	6.0	200	400	uA
IDD	Max quiescent analog supply current	Vin(logic) = Vcc or GND VIN[8:1] = Open VIN[8:1] = GND	6.0	11	11	mA
			6.0	23	24	

Table 6 AC Electrical Characteristics

SYMBOL	PARAMETER (4,6 & 7)	VCC (V)	LIMITS		UNIT
			-55 to +85°C	-55 to +125°C	
f _{MAX}	Maximum SCLK frequency. (50% duty cycle) (5) Maximum usable SCLK frequency = 1/(tp2 + tsu3)	2.0	4.8	4.0	MHz
		4.5	24	20	
		6.0	28	24	
		2.0	2.8	2.2	
		4.5	10.7	8.2	
		6.0	14.6	11.2	
t _w	Minimum SCLK pulse width. (50% duty cycle)	2.0	100	120	nS
		4.5	20	24	
		6.0	17	20	
t _{su1}	Minimum setup time, SCLK low to /CS↓.	2.0	100	100	nS
		4.5	50	50	
		6.0	40	40	
t _{h1}	Minimum hold time, /CS↓ to SCLK↑.	2.0	20	20	nS
		4.5	20	20	
		6.0	20	20	
t _{su2}	Setup time, DIN valid to /CS↓. (8)	5.0	35	35	uS
t _{h2}	Hold time, /CS↓ to DIN not valid. (8)	5.0	-1.5	-1.5	uS
t _{su3}	Minimum setup time, SDIN valid to SCLK↑.	2.0	75	80	nS
		4.5	20	25	
		6.0	15	15	
t _{h3}	Minimum hold time, SCLK↑ to SDIN not valid.	2.0	5	5	nS
		4.5	5	5	
		6.0	5	5	
t _{p1}	Maximum propagation delay, /CS↓ to DOUT valid. (1)	2.0	220	265	nS
		4.5	55	72	
		6.0	47	52	
t _{p2}	Maximum propagation delay, SCLK↑ to DOUT valid. (1)	2.0	295	380	nS
		4.5	90	102	
		6.0	70	75	
t _{p3}	Maximum propagation delay, /CS↑ to DOUT HI-Z. (1) (2) (3)	2.0	320	380	nS
		4.5	80	103	
		6.0	59	77	
t _{p4}	Minimum time between /CS active.	2.0	50	50	nS
		4.5	25	25	
		6.0	25	25	
C _{in}	Maximum logic input pin Capacitance. (5)		10	10	pF
C _{out}	Maximum DOUT pin capacitance, output in HI-Z state. (5)		15	15	pF

1. DOUT loaded with 50pF to GND.
2. DOUT loaded with 1K Ohms to GND for Hi output, 1K Ohms to VCC for Low output.
3. Timing measured at 25%VCC for “0” to Hi-Z, 75%VCC for “1” to Hi-Z.
4. Sample tested on lot basis.
5. Not tested
6. Unless otherwise noted, VDD=+15V, VIL = 0V, VIH = VCC
7. Measurements made at 50%VCC.
8. Vdd = 6V. t_{su2} represents the maximum possible propagation delay through the input comparator. t_{h2} represents the minimum possible propagation delay through the input comparator. The negative hold time denotes that DIN may change prior to /CS↓ and still be valid data at the S-Register.

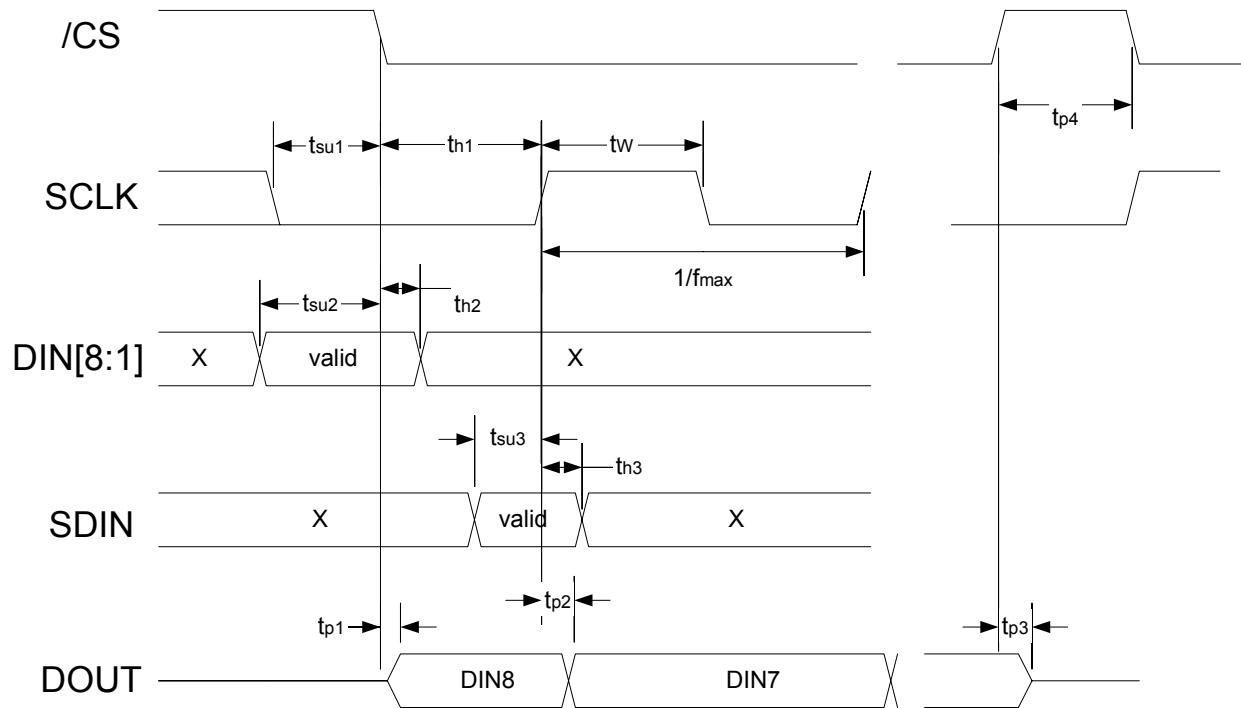

Figure 10 Switching Waveforms

PACKAGE DESCRIPTIONS

16 Lead Narrow Body SOIC

Moisture Sensitivity:

Level 2 per JEDEC J-STD-020A (1yr floor life)

Θ_{ja} :

73.6°C/W (Mounted on 4 layer PCB)

Θ_{jc} :

29.8°C/W

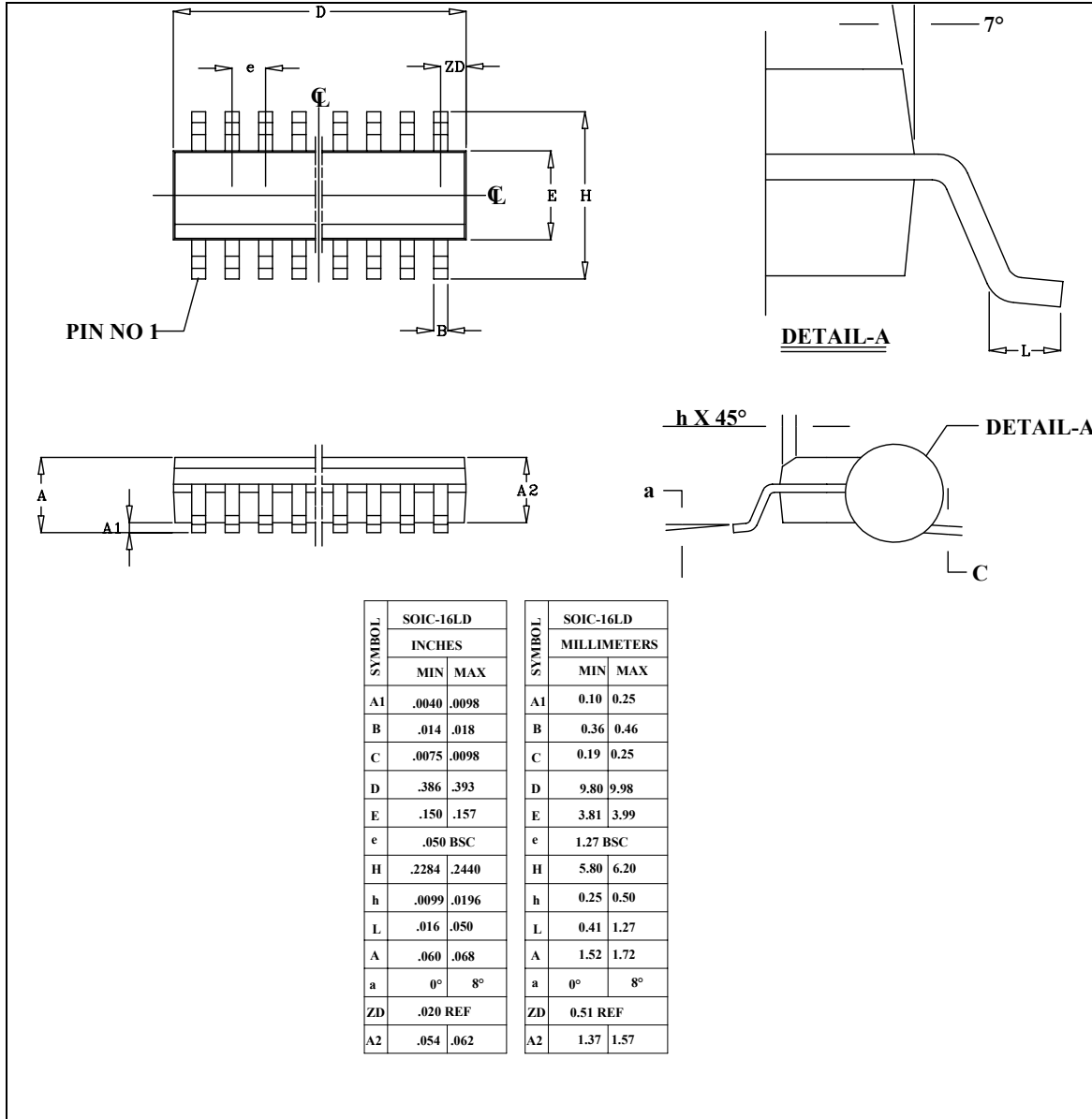

Figure 11 16 Lead Narrow Body SOIC Outline Drawing

16 Lead Ceramic Small Outline Package (CSOP)

Theta ja: 122 C/W Device mounted on 2 layer PCB
 Theta jc: 5 C/W
 Moisture Sensitivity Level: Hermetic

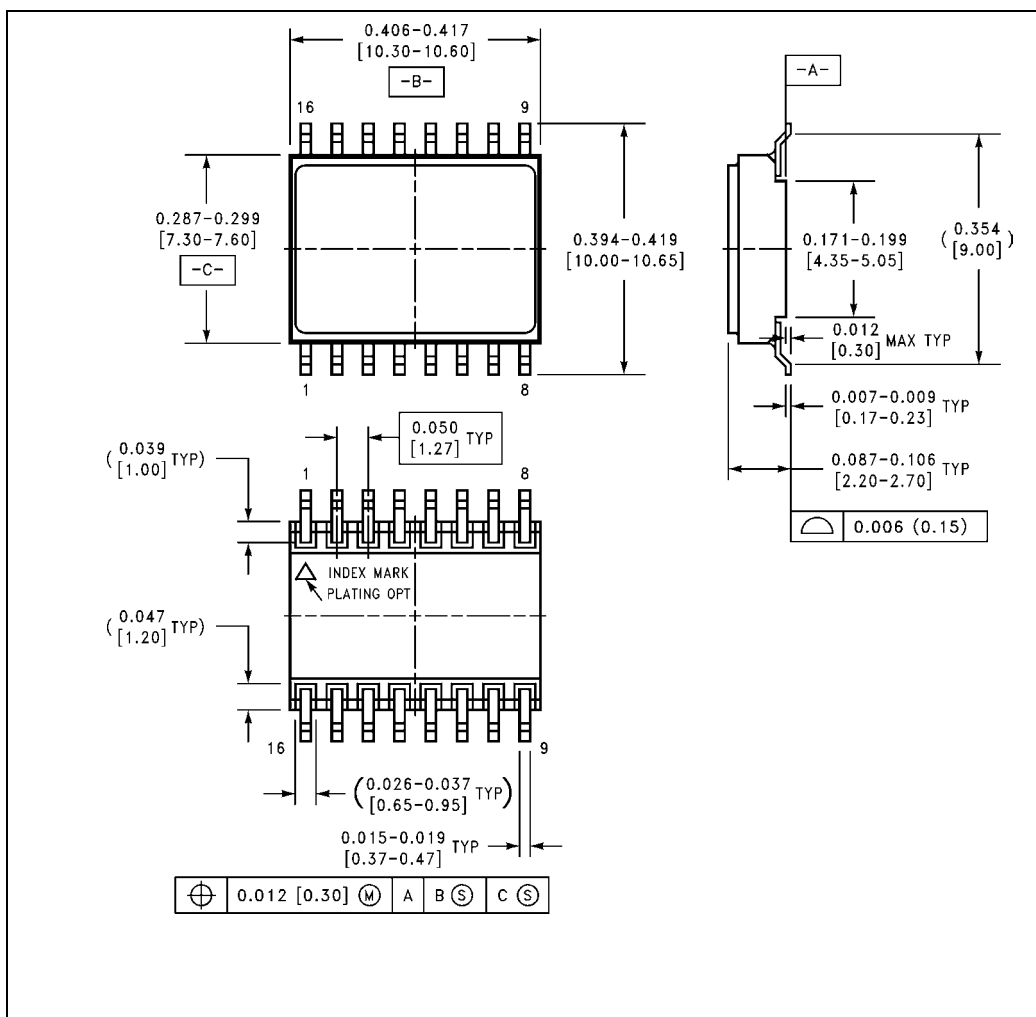

Figure 12 16 Lead CSOP Outline Drawing

ORDERING INFORMATION

Table 7

Part Number	Marking	Package	Burn In	Temperature
DEI1066-SES	DEI1066-SES	16 SOIC	No	-55 / +85 °C
DEI1066-SMS	DEI1066-SMS	16 SOIC	No	-55 / +125 °C
DEI1066-SMB	DEI1066-SMB	16 SOIC	96hr / +125 °C	-55 / +125 °C
DEI1066-WMS	DEI1066-WMS	16 CSOP	No	-55 / +125 °C
DEI1066-WMB	DEI1066-WMB	16 CSOP	96hr / +125 °C	-55 / +125 °C

DEI reserves the right to make changes to any products or specifications herein. DEI makes no warranty, representation, or guarantee regarding suitability of its products for any particular purpose.