

**DEVICE
ENGINEERING
INCORPORATED**

385 East Alamo Drive
Chandler, AZ 85225
Phone: (480) 303-0822
Fax: (480) 303-0824
E-mail: admin@deiaz.com

DEI1046, DEI1047, DEI1148 OCTAL ARINC 429 LINE RECEIVER

FEATURES

- Octal ARINC 429 to TTL/CMOS logic line receivers
- Operates from single +5V ± 10% or 3.3V ± 10% power supply
- ARINC inputs internally protected to lightning requirements of DO-160D Level A3
- Operates in high noise environment
 - Input Common Voltage Range: ± 20V
 - 2V minimum Input hysteresis
- Optional logic level TEST inputs on DEI1046.
- Package Options
 - 38L TSSOP, 4.4mm body (DEI1046/1047)
 - 44L MQFP, 13.9mm footprint (DEI1148)

DEI1046/1047 PINOUT

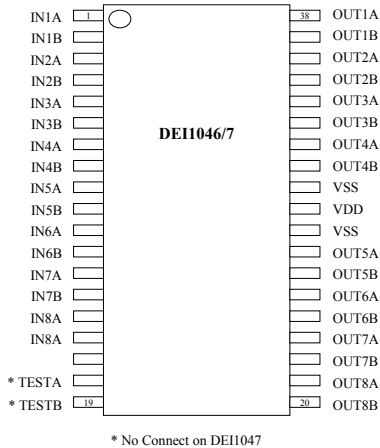

Table 1a DEI1046/1047 Pin Description

PIN	NAME	DESCRIPTION
15,13,11, 9, 7,5,3,1	IN[8:1]A	429 INPUTS. ARINC 429 format serial digital data "A" inputs.
16,14,12, 10, 8,6,4,2	IN[8:1]B	429 INPUTS. ARINC 429 format serial digital data "B" inputs.
18	TESTA	LOGIC INPUT. Test input A on DEI1046. No Connect on DEI1047.
19	TESTB	LOGIC INPUT. Test input B on DEI1046. No Connect on DEI1047.
21,23,25,27, 32,34,36,38	OUT[8:1]A	LOGIC OUTPUTS. CMOS/TTL format serial digital data "A" outputs.
20,22,24,26, 31,33,35,37	OUT[8:1]B	LOGIC OUTPUTS. CMOS/TTL format serial digital data "B" outputs.
29	VDD	POWER INPUT. 5 VDC OR 3.3VDC.
28, 30	VSS	POWER INPUT. Ground.

DEI1148 PINOUT

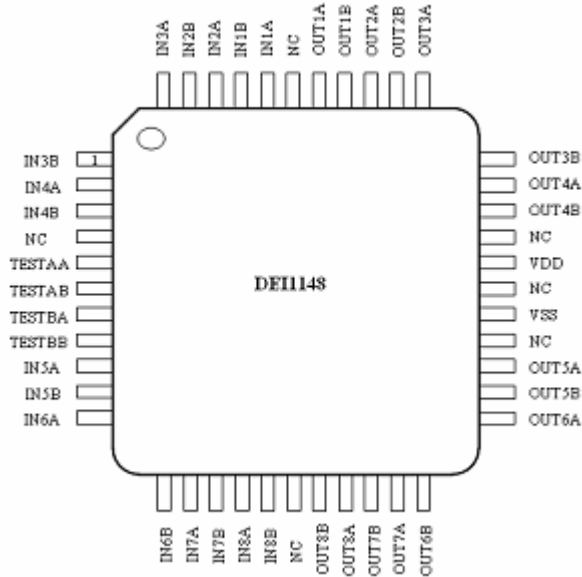

Table 1b DEI1148 Pin Description

PIN	NAME	DESCRIPTION
15, 13, 11, 9, 2, 44, 42, 40	IN[8:1]A	429 INPUTS. ARINC 429 format serial digital data "A" inputs.
16, 14, 12, 10, 3, 1, 43, 41	IN[8:1]B	429 INPUTS. ARINC 429 format serial digital data "B" inputs.
5	TESTAA	LOGIC INPUT. Test input A (+) for odd channels.
6	TESTAB	LOGIC INPUT. Test input A (-) for odd channels.
7	TESTBA	LOGIC INPUT. Test input B (+) for even channels.
8	TESTBB	LOGIC INPUT. Test input B (-) for even channels.
19, 21, 23, 25, 32, 34, 36, 38	OUT[8:1]A	LOGIC OUTPUTS. CMOS/TTL format serial digital data "A" outputs.
18, 20, 22, 24, 31, 33, 35, 37	OUT[8:1]B	LOGIC OUTPUTS. CMOS/TTL format serial digital data "B" outputs.
29	VDD	POWER INPUT. 5 VDC OR 3.3VDC.
27	VSS	POWER INPUT. Ground.

FUNCTIONAL DESCRIPTION

The DEI1046/7/1148 is a BiCMOS device which contains eight differential line receivers. Each receiver channel translates incoming ARINC 429 data bus signals (tri-level RZ bipolar differential modulation) to a pair of TTL/CMOS logic outputs. Each channel operates independently and meets the requirements of the ARINC 429 Digital Information Transfer Standard. Refer to Figure 1 "DEI1046/7/1148 Block Diagram and Truth Table".

The device is designed to operate in a high noise environment. Inputs are accepted over a +/- 20V common mode voltage range and the receivers provide over 2 Volts of hysteresis. Circuit speed is optimized to reject high frequency transients.

All ARINC input pins are designed with internal protection from damage due to transients meeting the lightning induced transient requirements of DO-160D Level A3.

The DEI1046 & 1148 device provides logic level TEST inputs for built in system test. They force the outputs of all eight receivers to the specified ZERO, ONE or NULL state. The ARINC inputs are ignored when the device is in test mode. The DEI1046 has a single test port which controls all 8 channels. The DEI1048 has two test ports, each controlling 4 channels. Test inputs are not bonded out on the DEI1047; they are internally connected to logic 0.

The ARINC inputs may optionally be connected to the ARINC bus through external 10K ohm series resistors. These resistors may be added in combination with transient voltage suppressors to achieve lightning protection beyond the level 3 limits.

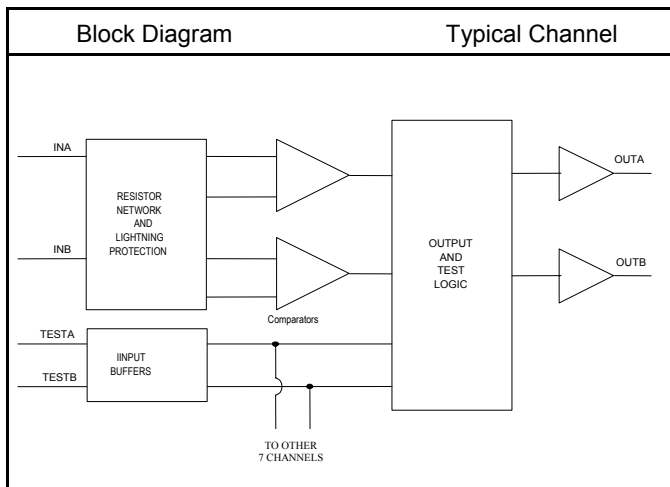

Truth Table					
INPUTS			OUTPUTS		
TEST INPUTS (TTL/CMOS)		ARINC INPUTS	TTL/CMOS		
TEST A	TEST B	A _{IN} - B _{IN} V	OUT A	OUT B	Logic
0	0	Logic +1	1	0	ONE
0	0	Logic -1	0	1	ZERO
0	0	NULL	0	0	NULL
0	1	X	0	1	ZERO
1	0	X	1	0	ONE
1	1	X	0	0	NULL

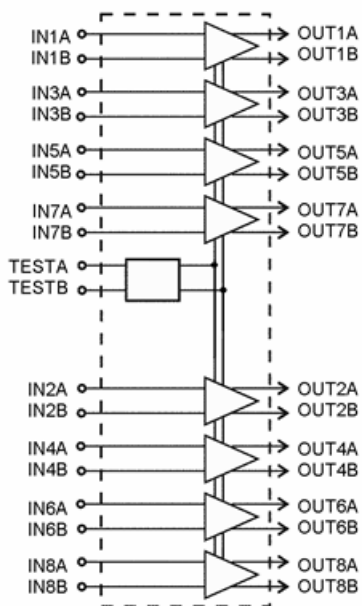

DEI1046 / 1047*

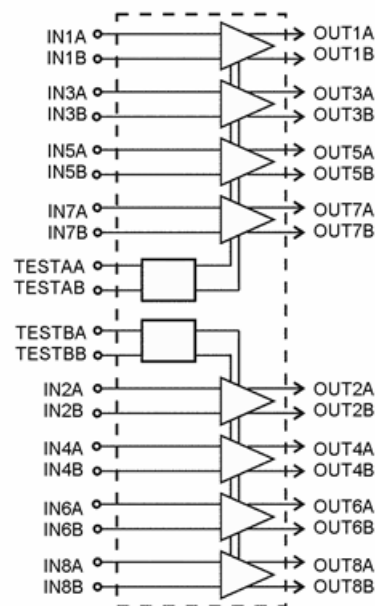

DEI1148

*Note: TEST inputs are not implemented on DEI1047. They are internally connected to logic 0.

Figure 1 DEI1046/1047/1148 Block Diagrams and Truth Table

ELECTRICAL DESCRIPTION

Table 2 Absolute Maximum Rating

PARAMETER	MIN	MAX	UNITS
Supply Voltage (with respect to V_{SS})	-0.3	7.0	V
Storage Temperature	-65	+150	°C
Input Voltage, continuous (ARINC Inputs)	-40	+40	V
Input Voltage (Test Inputs)	$V_{SS} - 0.3$	$V_{DD} + 0.3$	V
Power Dissipation @ 85 °C		800	mW
Junction Temperature: Tjmax, (limited by molding compound Tg)		145	°C
Lead Soldering Temperature (10 sec duration)		260	°C
Lightning Protection (ARINC 429 Channel Inputs and TESTA/TESTB Inputs) Waveform 3*	-600	+600	V
Waveform 4 and 5*	-300	+300	V
*Per DO160D level 3A. See Figures 4-6.			
ESD per JEDEC A114-A Human Body Model		2000	V
Caution: Stresses above these limits can cause permanent damage.			

Table 3 Recommended Operating Conditions

PARAMETER	SYMBOL	CONDITIONS
Supply Voltage	Vdd	+5V ± 10% +3.3V ± 10%
Logic Input Levels	VTESTA,B	0 to Vdd
Operating Temperature -xEx -xMx	Ta	-55 to +85°C -55 to +125°C

Table 4 Electrical Characteristics

Conditions: Temperature: -55°C to +85°C (-xEx); -55°C to +125°C (-xMx) $V_{DD} = +5V \pm 10\%$ or $3.3V \pm 10\%$						
PARAMETER	TEST CONDITION	SYMBOL	MIN	NOM	MAX	UNITS
ARINC INPUTS						
$V_A - V_B = \text{Logic } +1$	OUTA = 1	V_{+1}	6.5	10	13	V
$V_A - V_B = \text{Logic } -1$	OUTB = 1	V_{-1}	-6.5	-10	-13	V
$V_A - V_B = \text{Logic Null}$	OUTA = 0 OUTB = 0	V_{NULL}	-2.5	0	2.5	V
Input Hysteresis		V_{HY}	2.0		4.0	V
$V_A - V_B = \text{Null to } +1 \text{ transition}$	OUTA = 0→1	V_{T+1+}	5.5		6.5	V

Conditions: Temperature: -55°C to +85°C (-xEx); -55°C to +125°C (-xMx) V _{DD} = +5V ± 10% or 3.3V ± 10%						
PARAMETER	TEST CONDITION	SYMBOL	MIN	NOM	MAX	UNITS
V _A – V _B = +1 to Null transition	OUTA = 1→0	V _{T+1-}	2.5		3.5	V
V _A – V _B = Null to -1 transition	OUTB = 0→1	V _{T-1+}	-6.5		-5.5	V
V _A – V _B = -1 to Null transition	OUTB = 1→0	V _{T-1-}	-3.5		-2.5	V
Input Common Mode Voltage Range	Logic +1, Null, Logic -1	V _{CM}	-20		+20	V
Input Resistance IN _A to IN _B	V _{DD} open, Shorted to V _{SS} or +5V	R _{IN}	140K		390K	Ω
Input Resistance IN _A or IN _B to V _{SS}	V _{DD} open, Shorted to V _{SS} or +5V	R _S	140K		390K	Ω
Input Capacitance IN _A to IN _B	V _{DD} open, Shorted to V _{SS} or +5V	C _{IN}			10	pF
Input Capacitance IN _A or IN _B to V _{SS}	V _{DD} open, Shorted to V _{SS} or +5V	C _S			10	pF
TEST INPUTS						
Logic 0 Voltage		V _{IL}			0.8	V
Logic 1 Voltage		V _{IH}	2.0			V
Logic 0 Current	V _{IL} = 0.8	I _{IL}			25	μA
Logic 1 Current	V _{IH} = 2.0	I _{IH}			25	μA
LOGIC OUTPUTS						
OUT A or OUT B	I _{OH} = 5mA (5V V _{DD}) I _{OH} = 1.5mA (3.3V V _{DD}) TTL Compatible	V _{OH}	2.4			V
OUT A or OUT B	I _{OL} = 5mA (5V V _{DD}) I _{OL} = 1.5mA (3.3V V _{DD}) TTL Compatible	V _{OL}			0.4	V
OUT A or OUT B	I _{OH} = 100μA CMOS Compatible	V _{OH}	V _{DD} – 50mV			V
OUT A or OUT B	I _{OL} = 100μA CMOS Compatible	V _{OH}			V _{SS} + 50mV	V
SUPPLY CURRENT						
V _{DD} Current	Data Rate = 0MHz, A/BIN =open, A/BOU=open, V _{DD} = 5.5V or 3.63V	I _{DD}		20		mA

Table 5 Switching Characteristics

PARAMETER	TEST CONDITION	SYMBOL	MAX V _{DD} 3.3V	MAX V _{DD} 5V	UNITS
INA/B to OUT A/B Prop Delay	TESTA = TESTB = 0 C _L = 50pF	t _{LH}	300	200	ns
INA/B to OUT A/B Prop Delay	TESTA = TESTB = 0 C _L = 50pF	T _{HL}	300	200	ns
OUT A/B rise time	10% to 90%, C _L = 50pF	t _r	50	25	ns
OUT A/B fall time	10% to 90%, C _L = 50pF	t _f	50	25	ns
TESTA/B to OUTA/B Prop delay	C _L = 50pF	t _{TOH}	100	60	ns
TESTA/B to OUTA/B Prop delay	C _L = 50pF	t _{TOL}	100	60	ns

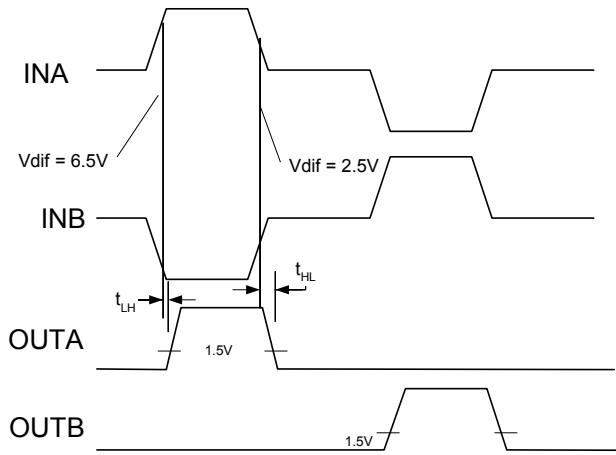

Figure 2 ARINC 429 Input to Logic Output Switching Waveform

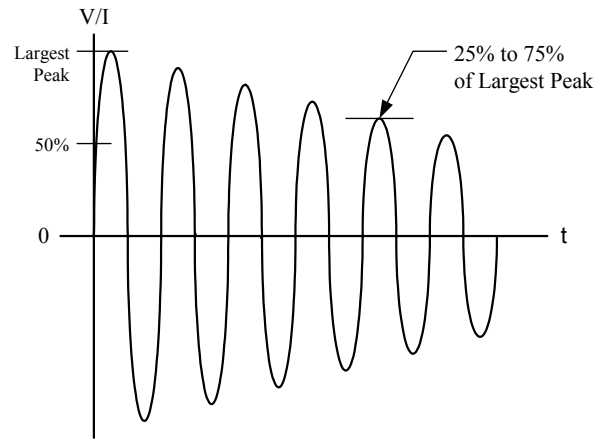

Figure 4 DO160D Lightning Induced Transient Voltage Waveform #3.
 Voc = 600V, Isc = 24A, Frequency = 1MHz \pm 20%

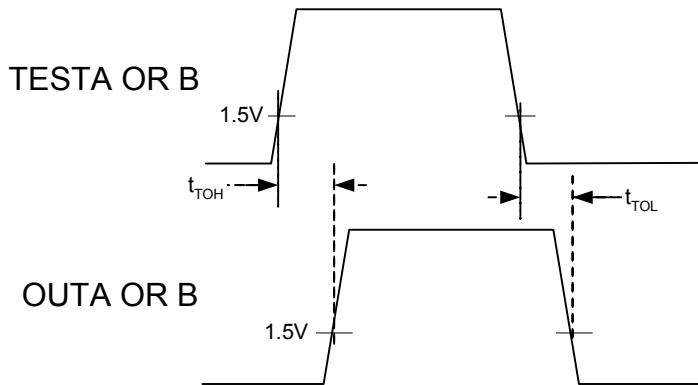

Figure 3 TEST Input to Logic Output Switching Waveform

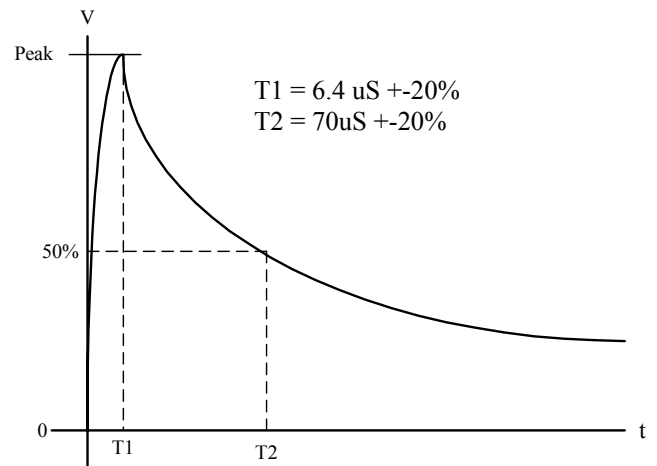

Figure 5 DO160D Lightning Induced Transient Voltage Waveform #4.
 Voc = 300V, Isc = 60A

LIGHTNING TRANSIENT NOTES:

1. Voc = Peak Open Circuit Voltage available at the calibration point.
2. Isc = Peak Short Circuit Current available at the calibration point.
3. Amplitude tolerances: +10%, -0%.
4. The ratio of Voc to Isc is the generator source impedance to be used for generating the waveforms.

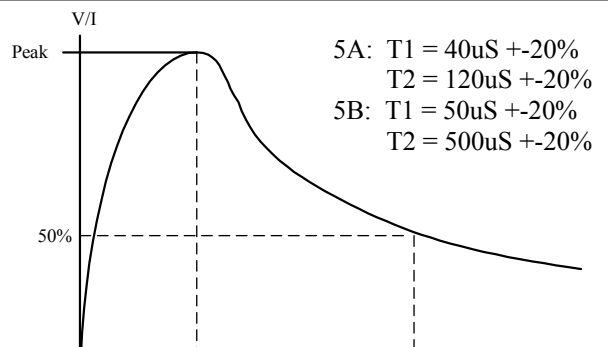

Figure 6 DO160D Lightning Induced Transient Voltage Waveform #5.
 Voc = 300V, Isc = 300A

ORDERING INFORMATION

Table 6: Ordering Information

DEI PN	MARKING (1)	TEST INPUTS	TEMPERATURE RANGE	PACKAGE	SCREENING
DEI1046-TES-G	DEI1046-TES E4	YES	-55/+85 °C	38L TSSOP G	Standard
DEI1046-TMS-G	DEI1046-TMS E4	YES	-55/+125 °C	38L TSSOP G	Standard
DEI1047-TES-G	DEI1047-TES E4	NO	-55/+85 °C	38L TSSOP G	Standard
DEI1047-TMS-G	DEI1047-TES E4	NO	-55/+125 °C	38L TSSOP G	Standard
DEI1148-QES-G	DEI1148-QES E3	YES	-55/+85 °C	44L MQFP G	Standard
DEI1148-QMS-G	DEI1148-QMS E3	YES	-55/+125 °C	44L MQFP G	Standard

Notes:

1. All packages marked with Lot Code and Date Code. "E4" after Date Code denotes Pb Free category.

Table 7: Screening Process

SCREENING	STANDARD
ELECTRICAL TEST:	
ROOM TEMPERATURE	100%
HIGH TEMPERATURE	100% @ 85°C or 125°C
LOW TEMPERATURE	0.65% AQL@-55°C

Table 8: Package Characteristics

PACKAGE TYPE	38L TSSOP, Green	44L MQFP, Green
REFERENCE	38L TSSOP G	44L MQFP G
THERMAL RESISTANCE:		
θ_{JA} (4 layer PCB with Power Planes)	75 °C/W	52 °C/W
θ_{JC}	15 °C/W	12 °C/W
JEDEC MOISTURE SENSITIVITY LEVEL (MSL)	MSL 2 / 260°C	MSL 3 / 260°C
LEAD FINISH MATERIAL / JEDEC Pb-free CODE	NiPdAu e4	Matte Sn e3
Pb-Free DESIGNATION	RoHS Compliant	RoHS Compliant
JEDEC REFERENCE	MO-153-BD-1	MO-112 VAR AA-1

DEI reserves the right to make changes to any products or specifications herein. DEI makes no warranty, representation, or guarantee regarding suitability of its products for any particular purpose.

PACKAGE DESCRIPTIONS

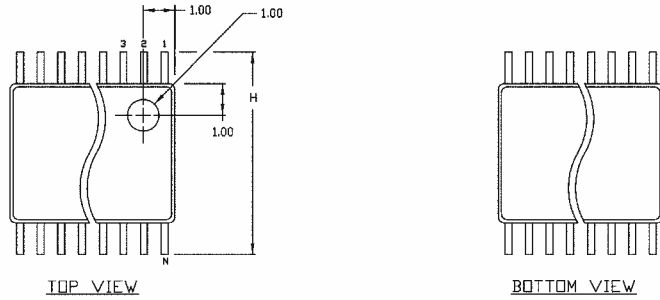

SYMBOL	COMMON DIMENSIONS			
	MILLIMETERS		INCHES	
	MIN.	MAX.	MIN.	MAX.
A	-----	1.10	-----	.043
A ₁	0.05	0.15	.002	.006
A ₂	0.85	0.95	.033	.037
b	0.17	0.27	.0067	.0106
b ₁	0.17	0.23	.0067	.0091
c	0.090	0.200	.0035	.0079
c ₁	0.090	0.135	.0035	.0053
D	9.60	9.80	.3780	.3858
E	4.30	4.50	.169	.177
e	0.50	BSC	0.0197	BSC
H	6.30	6.50	.248	.256
L	0.50	0.70	.020	.028
α	0°	8°	0°	8°

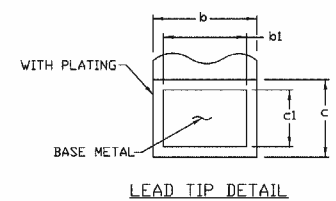
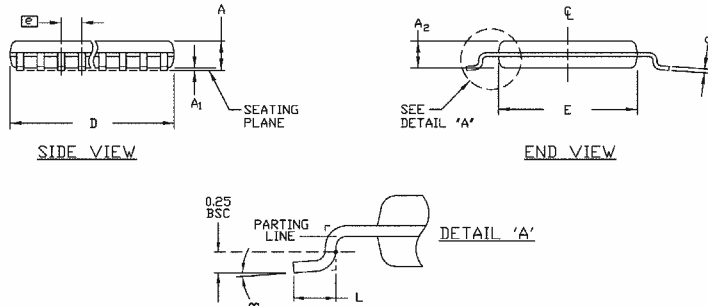
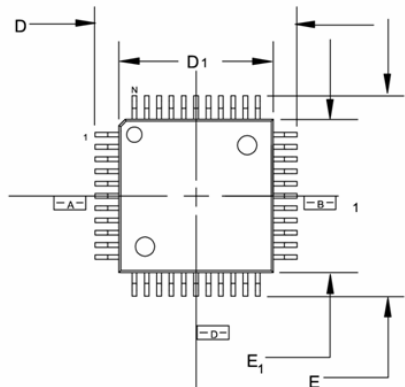
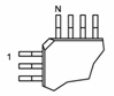
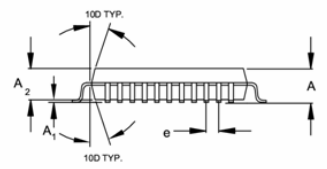

Figure 7 38L TSSOP Mechanical Outline



- NOTES**
1. ALL DIMENSIONS IN MILLIMETERS
 2. DIMENSIONS SHOWN IN CHART ARE NOMINAL WITH TOLERANCES AS INDICATED
 3. FOOT LENGTH "L" IS MEASURED AT GAGE PLANE AT 0.25 ABOVE THE SEATING PLANE.

DIMS.	TOL.	LEADS	3.90 mm
A	MAX.	44L	2.45
A ₁	MIN./MAX.		.25/.50
A ₂	+ .10/- .05		2.00
D	P. 25		13.90
D ₁	P. 10		10.00
E	P. 25		13.90
E ₁	P. 10		10.00
L	+ .15/- .10		.88
e	BASIC		.80
b	P. 05		.30
Q			0D-7D
ddd			.12 NOM.
ccc	MAX.		.10



ANOTHER VARIATION OF PIN 1 VISUAL AID

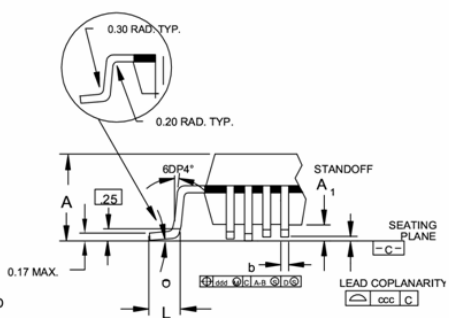

Figure 8: 44L 13.90mm MQFP Mechanical Outline