

# DEVICE ENGINEERING INCORPORATED

385 E. Alamo Drive  
Chandler, AZ 85225  
Phone: (480) 303-0822  
Fax: (480) 303-0824  
E-mail: admin@deiaz.com

## DEI1038 ARINC 429 Line Driver Integrated Circuit

### Features:

- ARINC 429 Line Driver for high speed (100KHz) and low speed (12.5KHz) data rates.
- Pin Compatible with HI-8383J including 13Ω output resistor.
- Low EMI RS-422 Line Driver mode for data rates up to 100 KHz.
- Adjustable Slew rates via external capacitors.
- Inputs TTL and CMOS Compatible.
- Low Quiescent Power of 125mW (typical)
- Programmable output differential range via  $V_{REF}$  pin.
- Outputs are not fused.
- Drives full ARINC load of 400Ω and 0.03μF.
- -55°C to +85°C operating temperature range.
- 100% Final testing.



### Functional Description:

The ARINC 429 Line Driver Circuit is a bipolar monolithic IC designed to meet the requirements of several general aviation serial data bus standards. These include the differential bipolar RZ types such as ARINC 429, ARINC 571, and ARINC 575 as well as the differential NRZ types such as RS-422.

The DEI1038 operates in either a 429 mode or a 422 mode as controlled by the 429/422' pin. In 429 mode, the serial data is presented on DATA(A) and DATA(B) inputs in the dual rail format of the HS-3182. The driver is enabled by the SYNC and CLOCK inputs. The output voltage level is programmed by the  $V_{REF}$  input and is normally tied to +5VDC along with  $V_1$  to produce output levels of +5 volts, 0 volts, and -5 volts on each output for ±10 volts differential outputs.

In 422 mode, the serial data is presented on DATA(A) input. The driver is enabled by the SYNC and CLOCK inputs. The outputs swing between 0 volts and +5 volts if  $V_{REF}$  is at +5VDC.

The driver output resistance is 26 Ω ±20% at room temperature; 13 Ω on each output. The outputs are not fused. The output slew rate is controlled by external timing capacitors on CA and CB. Typical values are 75pF for 100KHz data and 500pF for 12.5KHz data.

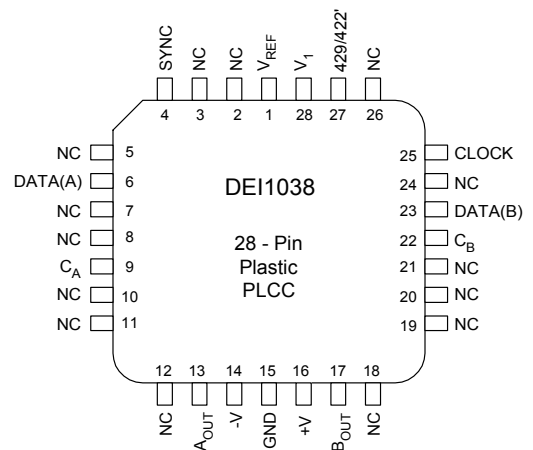

Figure 1: DEI1038 Pinout

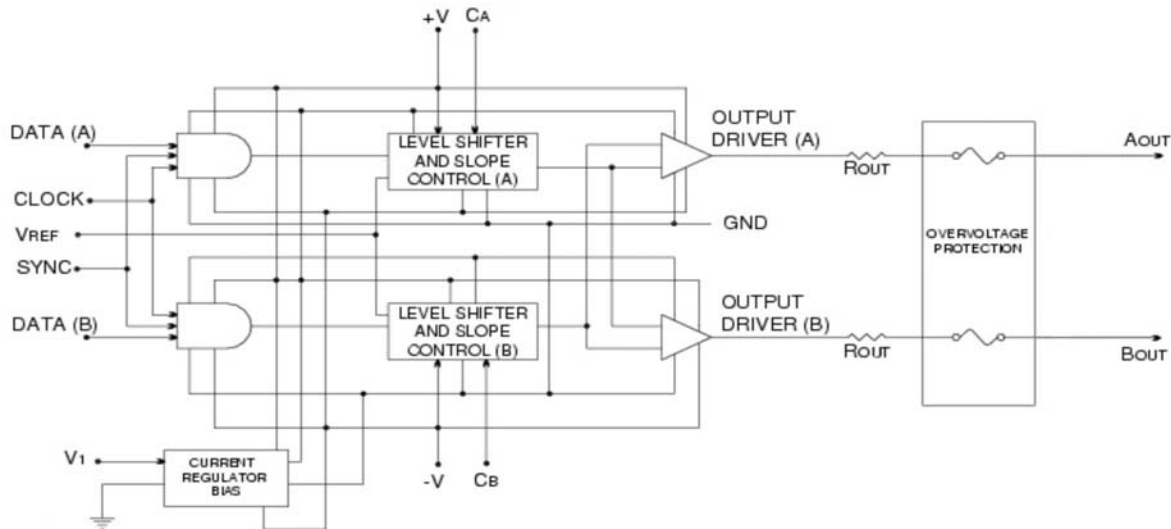

Figure 2: Block Diagram

Table 1: Pin Descriptions

Pin #	Pin Name	Description
1	$V_{REF}$	Analog Input. The voltage on $V_{REF}$ sets the output voltage levels on $A_{OUT}$ and $B_{OUT}$ . The output logic levels swing between $+V_{REF}$ , 0 volts, and $-V_{REF}$ volts.
4	SYNC	Logic input. Logic 0 forces outputs to NULL state. Logic 1 enables data transmission.
25	CLOCK	Logic input. Logic 0 forces outputs to NULL state. Logic 1 enables data transmission.
6 23	DATA(A) DATA(B)	Logic inputs. These signals contain the Serial Data to be transmitted on the ARINC 429 data bus. Refer to Figure 3.
9 22	$C_A$ $C_B$	Analog Nodes. External timing capacitors are tied from these points to ground to establish the output signal slew rate. Typical $C_A = C_B = 75\text{pF}$ for 100 kHz data and $C_A = C_B = 500\text{pF}$ for 12.5 kHz data. *
13 17	$A_{OUT}$ $B_{OUT}$	Outputs. These are the line driver outputs which are connected to the aircraft serial data bus.
14	-V	Negative Supply Input. -15VDC nominal.
15	GND	Ground.
16	+V	Positive Supply Input. +15VDC nominal.
27	429/422'	Logic Input. Mode control for ARINC 429 and RS-422 modes. An internal 10K $\Omega$ pull up resistor keeps the chip in ARINC 429 mode when there is no external connection. This creates a default logic 1, enabling the ARINC 429 mode. A forced logic 0 enables the RS-422 mode.
28	$V_1$	Logic Supply Input. +5VDC nominal.
2, 3, 5, 7, 8, 10	NC	No Connect
11, 12, 18, 19	NC	No Connect
20, 21, 24, 26	NC	No Connect

\* $C_A$  and  $C_B$  pin voltages swing between  $\pm 5$  volts. Any electronic switching of the capacitor on the pins must not inhibit the full voltage swings.

**Table 2: Logic Function**

	429/422' (1)	SYNC (2)	CLOCK (2)	DATA(A) (2)	DATA(B) (2)	A <sub>OUT</sub>	B <sub>OUT</sub>	COMMENTS
4 2 9 M O D E	H	L	X	X	X	0	0	NULL
	H	X	L	X	X	0	0	NULL
	H	H	H	L	L	0	0	NULL
	H	H	H	H	H	0	0	NULL
	H	H	H	H	L	+V <sub>REF</sub>	-V <sub>REF</sub>	LOGIC 1
	H	H	H	L	H	-V <sub>REF</sub>	+V <sub>REF</sub>	LOGIC 0
4 2 2 M O D E	L	L	X	X	X	+V <sub>REF</sub>	0	NULL
	L	X	L	X	X	+V <sub>REF</sub>	0	NULL
	L	H	H	L	X	0	+V <sub>REF</sub>	LOGIC 0
	L	H	H	H	X	+V <sub>REF</sub>	0	LOGIC 1

**NOTES:**

1. The 429/422' pin is internally pulled up to V<sub>1</sub> through a 10kΩ resistor. If no external connection is made to this pin, it will default to the 429 mode.
2. X = Don't care.

**Table 3: Maximum Ratings**

PARAMETER	MIN	MAX	UNITS
<b>VOLTAGE BETWEEN PINS:</b>			
+V and GND	0	+40.0	V
-V and GND	0	-40.0	V
V <sub>1</sub> and GND	-0.3	+7.0	V
V <sub>REF</sub> and GND	-0.3	+6.0	V
LOGIC INPUTS	(GND-0.3)	(V <sub>1</sub> + 0.3)	V
Storage Temperature	-65	+150	°C
Lead Soldering Temperature (10 Seconds Max)	-	260	°C
Max Junction Temperature (T <sub>J MAX1</sub> )Die Limit (short term operation)		+175	°C
Max Junction Temperature (T <sub>J MAX2</sub> )Plastic Package Limit (prolonged operation)		+145	°C
Output Short Circuit Duration	See Note 1		
Output Over Voltage Protection	See Note 2		
Power Dissipation	See Table 5		

**NOTES:**

1. One output at a time can be shorted to ground indefinitely.
2. The outputs are not fused. External fusing must be provided to meet the Transmitter Fault Isolation of the ARINC 429 SPECIFICATION.

**Table 4: Recommended Operating Range**

PARAMETER	MIN	TYP	MAX	UNITS
+V	+11.4		+16.5	VDC
-V	-11.4		-16.5	VDC
V <sub>I</sub>	+4.5	+5.0	+5.5	VDC
V <sub>REF</sub> (for ARINC 429)	+4.5	+5.0	+5.5	VDC
V <sub>REF</sub> (for other applications)	+3.0		+6.0	V
Operating Temperature (T <sub>A</sub> )	-55		+85	°C

**Table 5: Power Dissipation**

100% Duty Cycle Full Load = 400Ω/30,000pF Half Load = 4,000Ω/10,000pF						
DATA RATE	LOAD	+V = 15V	-V = -15V	V <sub>I</sub> , V <sub>REF</sub> = 5V	Pd POWER	LOAD POWER
0 to 100kbps	NONE	2.0mA	-5.0mA	4mA	125mW	0.0mW
12.5kbps	FULL	16.0mA	19.0mA	4mA	485mW	60.0mW
100kbps	FULL	48.0mA	51.0mA	4mA	1194mW	325.0mW
12.5kbps	HALF	6.0mA	8.0mW	4mA	196mW	30.0mW
100kbps	HALF	22.0mA	25.0mA	4mA	561mW	162.5mW

## Thermal Management

Device power dissipation varies greatly as a function of data rate, load capacitance, data duty cycle, and supply voltage. Proper thermal management is important in designs operating at the HI speed data rate (100KBS) with high capacitive loads and high data duty cycles.

Power dissipation may be estimated from Table 5 “Power Dissipation Table”. Device power dissipation (Pd) is indicated for 100% data duty cycle with no word gap null times and should be adjusted for the appropriate data duty cycle (DC). Pd(application) = DC \* [Pd(table) - 145mW] + 145mW, where DC is the application data duty cycle, Pd(table) is the Pd from the table for the indicated data rate and bus load, and 145mW is the quiescent power. The application’s data duty cycle (DC) for 100KBS operation is calculated as:

$$DC = (\text{total bits transmitted in 10 sec period} / 1,000,000) = (32 \times \text{total ARINC words transmitted in 10 sec period} / 1,000,000).$$

Heat transfer from the IC package should be maximized. Use maximum trace width on all power and signal connections at the IC. Place vias on the signal/power traces close to the IC to maximize heat flow to the internal power planes. If possible, design a solid heat spreader land under and beyond the IC to maximize heat flow from the device.

**Table 6: DC Electrical Characteristics**

Conditions: Temperature: = -55°C to +85°C; +V = +11.4 to +16.5VDC, -V = -11.4 to -16.5VDC;  
 $V_1 = V_{REF} = +5VDC \pm 5\%$ , 429/422<sup>1</sup> = Open Circuit (unless otherwise noted.)

SYMBOL	PARAMETER	MIN	TYP	MAX	UNIT	TEST CONDITIONS
IQ+V	Quiescent +V supply current	-	2	-	mA	No Load. 429 mode. DATA = CLOCK = SYNC = LOW
IQ-V	Quiescent -V supply current	-	5	-	mA	No Load. 429 mode. DATA = CLOCK = SYNC = LOW
IQV <sub>1</sub>	Quiescent V <sub>1</sub> supply current	-	4	-	mA	No Load. 429 mode. DATA = CLOCK = SYNC = LOW
IQV <sub>REF</sub>	Quiescent V <sub>REF</sub> supply current	-	10	-	mA	No Load. 429 mode. DATA = CLOCK = SYNC = LOW
V <sub>IH</sub>	Logic 1 In. V	2.0	-	-	V	No Load.
V <sub>IL</sub>	Logic 0 In. V	-	-	0.6	V	No Load.
I <sub>IH</sub>	Logic 1 In. I	-	-	10	mA	No Load.
I <sub>IL</sub>	Logic 0 In. I	-	-	-20	mA	No Load. (Pin 27 I <sub>IL</sub> = -2mA max)
I <sub>OHSC</sub>	Output Short Circuit Current (Output High)	-80	-	-	mA	Short to Ground
I <sub>OLSC</sub>	Output Short Circuit Current (Output Low)	80	-	-	mA	Short to Ground
V <sub>OH</sub>	Output Voltage HIGH. (+1)	V <sub>REF</sub> - 250mV	V <sub>REF</sub>	V <sub>REF</sub> + 250mV	V	No Load. 429 Mode.
V <sub>NULL</sub>	Output Voltage NULL. (0)	-250	-	+250	mV	No Load. 429 Mode.
V <sub>OL</sub>	Output Voltage LOW. (-1)	-V <sub>REF</sub> - 250mV	-V <sub>REF</sub>	-V <sub>REF</sub> + 250mV	V	No Load. 429 Mode.
I <sub>CT</sub> + -	Timing Capacitor Charge Current C <sub>A</sub> (+1) C <sub>B</sub> (-1) C <sub>A</sub> (-1) C <sub>B</sub> (+1)	-	+200 -200	-	mA mA	No Load. 429 Mode. SYNC = CLOCK = HIGH C <sub>A</sub> and C <sub>B</sub> held at zero volts.
ISC (+V)	+V Short Circuit Supply Current	-	-	+150	mA	Output short to ground
ISC (-V)	-V Short Circuit Supply Current	-	-	-150	mA	Output short to ground
R <sub>OUT</sub>	Resistance on each output	-	13	-	Ohms	Room Temp Only
C <sub>IN</sub>	Input Capacitor	-	-	15	pF	-

## AC ELECTRICAL CHARACTERISTICS

Figures 3 and 4 show the output waveforms for the ARINC 429 and RS-422 modes of operation.

The output slew rates are controlled by timing capacitors  $C_A$  and  $C_B$ . They are charged by  $\pm 200\mu\text{A}$  (nom.).

Slew rate (SR) measured as  $\text{V}/\mu\text{sec}$ , is calculated by:

$$\text{SR} = 200/C$$

where C is in pF.

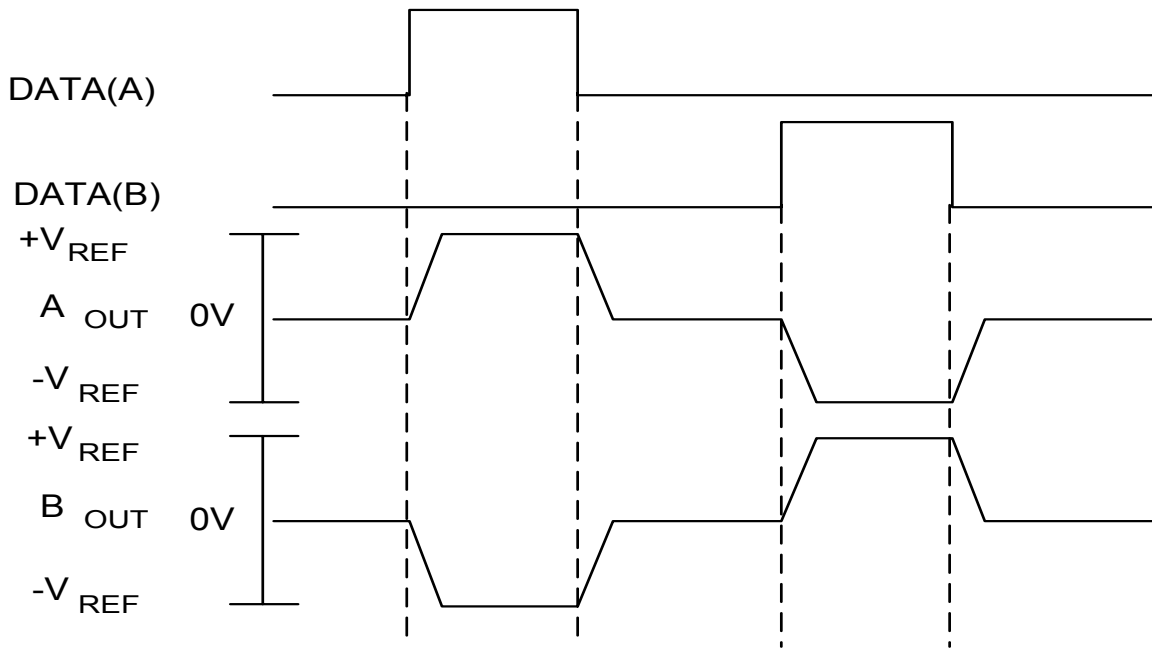

Figure 3: ARINC 429 Waveforms

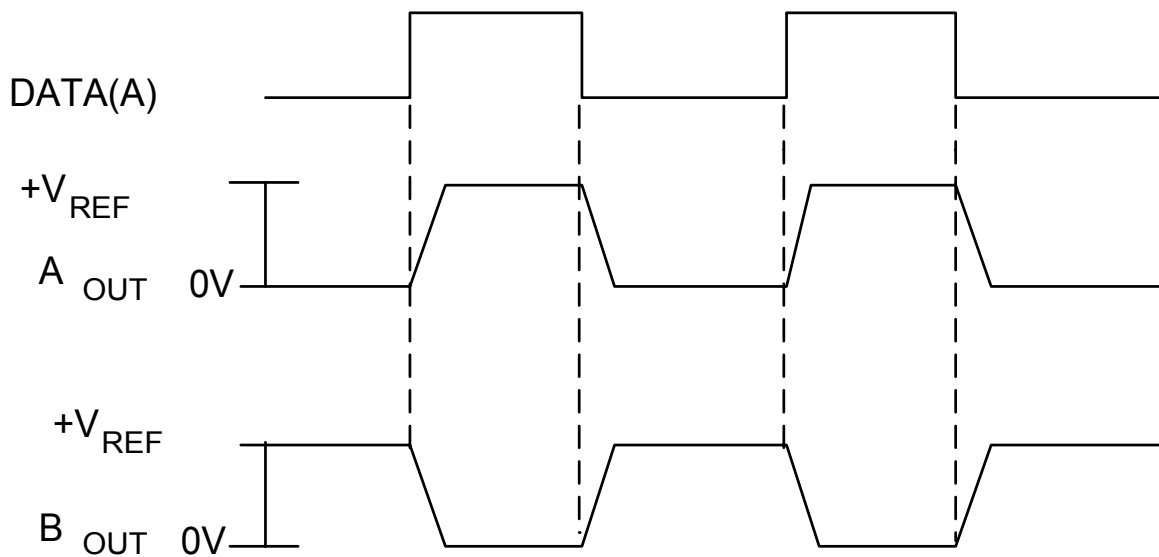
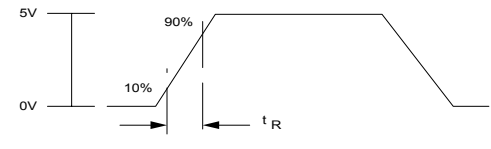
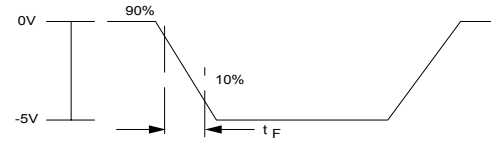
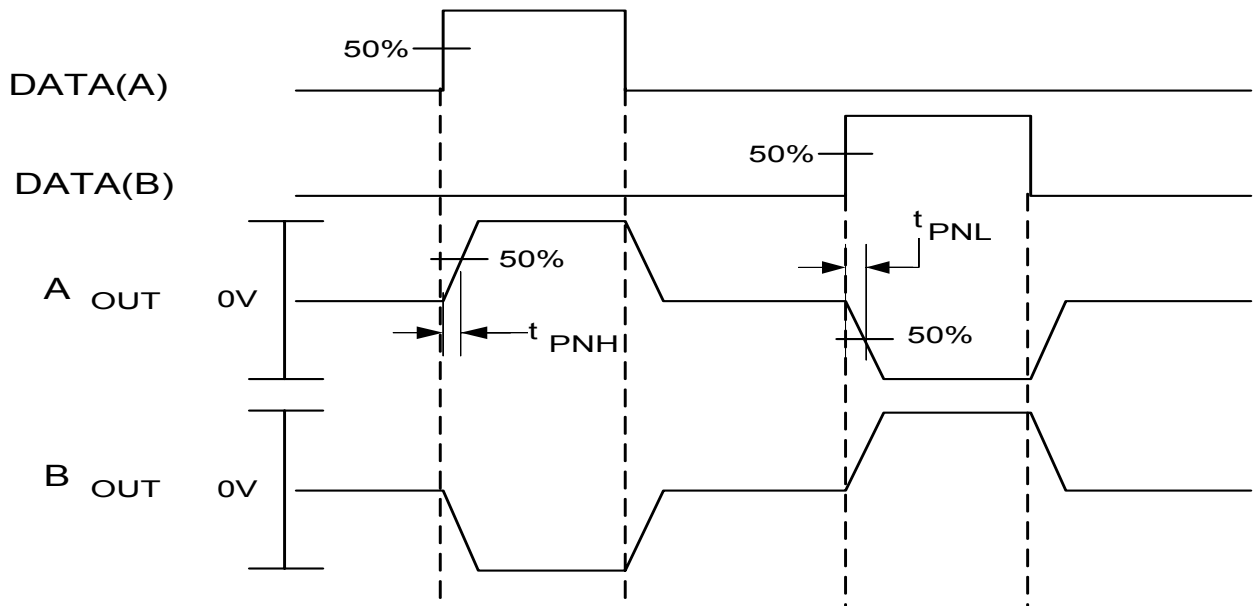

Figure 4: RS-422 Waveforms

**Table 7: AC Electrical Characteristics**

Parameter	Symbol	MIN	MAX	UNITS	NOTES
Output Rise Time $A_{OUT}$ or $B_{OUT}$ $C_A = C_B = 75\text{pF}$ $C_A = C_B = 500\text{pF}$	$t_R$ $t_R$	1.0 5.0	2.0 15.0	$\mu\text{sec}$ $\mu\text{sec}$	
Output Fall Time $A_{OUT}$ or $B_{OUT}$ $C_A = C_B = 75\text{pF}$ $C_A = C_B = 500\text{pF}$	$t_F$ $t_F$	1.0 5.0	2.0 15.0	$\mu\text{sec}$ $\mu\text{sec}$	
Input to Output Propagation Delay	$t_{PNH}$ $t_{PNL}$	-	3.0	$\mu\text{sec}$	See Figure 5
$A_{OUT} / B_{OUT}$ Skew Spec.	-	-	500	nsec	



**Figure 5: Propagation Delay**

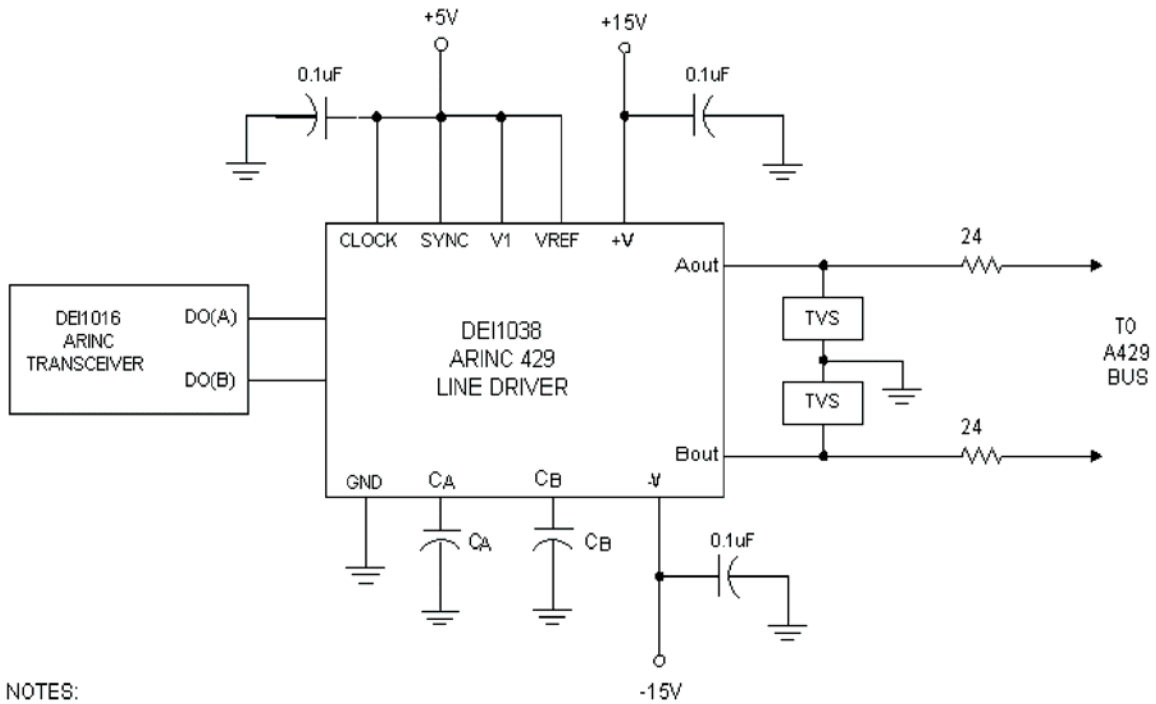

- NOTES:
1. Select CA / CB value for desired Output Slew Rate.
  2. TVS: TRANSIENT VOLTAGE SUPPRESSOR.

Figure 6: Typical Application

**Component Screening:**

Table 8: Screening Process	
SCREENING	STANDARD PLASTIC
ELECTRICAL TEST:	
ROOM TEMPERATURE	100%
HIGH TEMPERATURE	100% @ +125 °C
LOW TEMPERATURE	0.65% AQL@-55°C

**Ordering Information:**

Table 9: Ordering Information				
DEI PART NUMBER	MARKING (1)	PACKAGE	TEMPERATURE RANGE	SCREENING
DEI1038	DEI1038	28 PLCC	-55 / +85 °C	STANDARD
DEI1038-G	DEI1038 E3	28 PLCC G	-55 / +85 °C	STANDARD

Notes:  
 1. All packages marked with Lot Code and Date Code. "E4" after Date Code denotes Pb Free category.

## Package Description:

Table 10: Package Characteristics Table		
PACKAGE TYPE	28L PLCC	28L PLCC, Green
REFERENCE	28 PLCC	28 PLCC G
<b>THERMAL RESISTANCE:</b>		
$\theta_{JA}$ (4 layer PCB with Power Planes)	55 °C/W	55 °C/W
$\theta_{JC}$	25 °C/W	25 °C/W
JEDEC MOISTURE SENSITIVITY LEVEL (MSL)	MSL 3 / 235°C	MSL 3 / 245°C
LEAD FINISH MATERIAL / JEDEC Pb-free CODE	SnPb	Matte Sn e3
Pb-Free DESIGNATION	Not Pb-free	RoHS Compliant
JEDEC REFERENCE	MS-018-AB	MS-018-AB

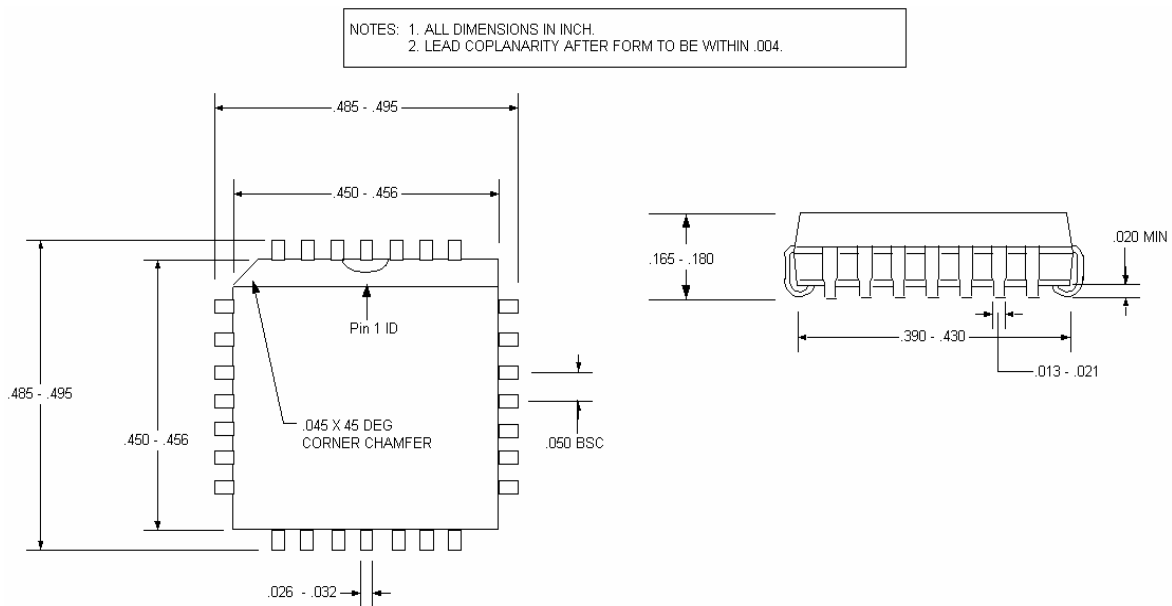

Figure 7: 28L PLCC Package Dimensions

DEI reserves the right to make changes to any products or specifications herein. DEI makes no warranty, representation, or guarantee regarding suitability of its products for any particular purpose.